

Chapter I

Introduction

1.1 Liquid Crystals

In 1888 Reinitzer recognized that apart from familiar states of matter *viz.*, solid, liquid and gas, there exists a fourth state of aggregation in some organic compounds with elongated molecules. This is an intermediate state between the disordered liquid and ordered solid and is called the liquid crystalline state. In liquid crystals the anisotropic molecules exhibit long-range orientational order and in some compounds they also exhibit long-range positional order of the centers of mass of the molecules in one or two dimensions. Like a liquid the medium can flow, however it also exhibits anisotropies in physical properties like refractive indices, dielectric constants, conductivities, magnetic susceptibilities etc. There are basically two classes of liquid crystals, *viz.* thermotropic and lyotropic. In thermotropic liquid crystals the mesomorphic behavior arises because of temperature. Lyotropic liquid crystals are formed when amphiphilic compounds are dissolved in some solvent like water. In this thesis we study several physical properties on some thermotropic liquid crystals made of rod like molecules.

1.2 Nematic Liquid Crystals

The simplest among all the liquid crystalline phases so far known is the nematic. The distribution of the centres of mass of the molecules in the medium is liquid like. The long axes of the molecules on an average are aligned about a specific direction, which is denoted by a unit vector, called the director (\hat{n}). Nematic is apolar in nature i.e. \hat{n} and $-\hat{n}$ are physically equivalent. Thermotropic nematic liquid crystals are uniaxial positive with the largest principal refractive index corresponding to polarisation of light along \hat{n} . There is no unambiguously identified thermotropic biaxial nematic liquid crystal made of rod like molecules. A schematic diagram of the uniaxial nematic liquid crystal is shown in Fig.(1.1).

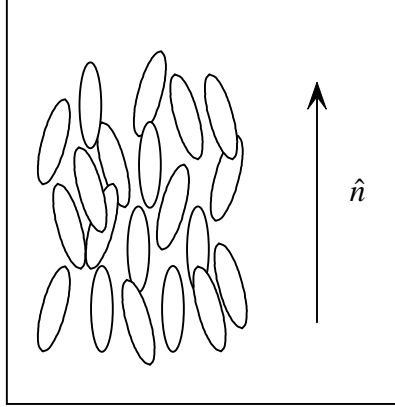

Figure 1.1: Schematic representation of the molecular arrangement of rod like molecules in the nematic phase. The arrow indicates the direction of average orientation of the molecules (\hat{n} , the director).

1.2.1 Orientational Order Parameter

The order parameter is a measure of type of order in the relevant phase. For example, the ferromagnetic phase is characterized by an order parameter called magnetization, which becomes zero in the paramagnetic phase. In nematic liquid crystals the orientational order parameter describes the average orientation of the long axes of the molecules along the director. To define the local orientation at a point $\vec{r} = (x, y, z)$, following de Jeu [1], let us assume that the molecule is a rigid rod with a unit vector \hat{a} along the long axis. Now consider the thermal average of the relevant tensors that are composed of \hat{a} , over a microscopic volume around \vec{r} . The first choice is a vector order parameter $\langle \hat{a} \rangle$, where the angular brackets denote the ensemble average. This is analogous to the magnetization in a ferromagnet. However $\langle \hat{a} \rangle$ will be zero in the nematic phase because of \hat{n} and $-\hat{n}$ are physically equivalent. The next choice of order parameter is a second rank tensor S , the elements of which are given by

$$S_{\alpha\beta} = \langle a_{\alpha} a_{\beta} \rangle - \frac{1}{3} \delta_{\alpha\beta}, \quad \alpha, \beta = x, y, z. \quad (1.1)$$

Notice that the addition of Kronecker delta ensures that $S_{\alpha\beta}$ is zero in the isotropic phase where $\langle a_\alpha^2 \rangle = 1/3$. The tensor order parameter is symmetric and traceless and has five independent elements. In the principal coordinate system the above tensor can be written in diagonal form. For the uniaxial case, the most general form of order parameter field in the nematic phase is given by

$$S_{\alpha\beta}(\vec{r}) = S \left(n_\alpha(\vec{r})n_\beta(\vec{r}) - \frac{1}{3} \delta_{\alpha\beta} \right) \quad (1.2)$$

where S is a measure of the degree of alignment of the long axes of the molecules along $\hat{n}(\vec{r})$ and the expression in the parenthesis describes the spatial variation of $\hat{n}(\vec{r})$ from point to point. \hat{n} is independent of \vec{r} in a well-aligned nematic. A schematic representation of the distribution function of the rod like molecules is shown in Fig.(1.2b).

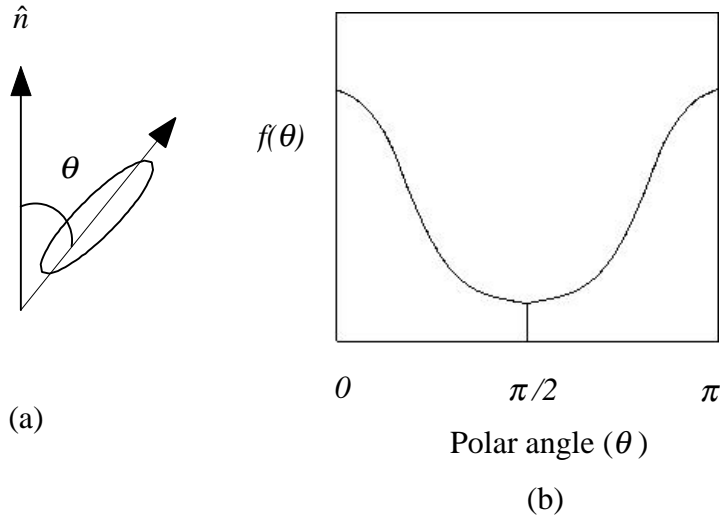

Figure 1.2: The distribution function $f(\theta)$ for a system of rod like molecules in the nematic phase. $f(\theta)$ is large around $\theta = 0, \pi$ (i.e. for molecules parallel to the optic axis) and is small for $\theta = \pi/2$.

For cylindrically symmetric molecules the scalar order parameter is defined as [2]

$$S = \frac{3\langle \cos^2 \theta \rangle - 1}{2} \quad (1.3)$$

where the angular brackets represent the ensemble average and θ is the angle made by the molecule with the director (Fig.(1.2a)). Nematic to isotropic phase transition is first order in nature and the corresponding heat of transition is ~ 0.2 kcal/mole. At the transition the order parameter is ~ 0.3 to 0.4 and it can go up to 0.8 at very low temperatures in the nematic phase.

The order parameter can be directly related to certain experimentally determined quantities- like, for example diamagnetic anisotropy, birefringence etc. Let us choose a space-fixed cartesian coordinate system xyz with \hat{z} parallel to \hat{n} (Fig.(1.3)).

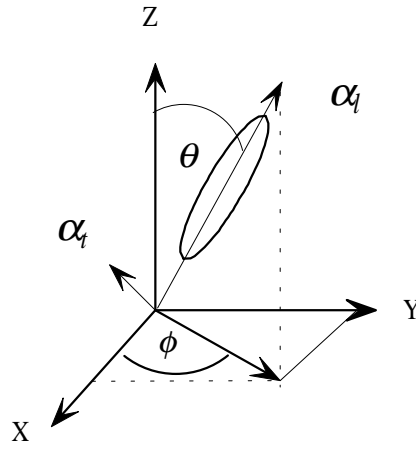

Figure 1.3: Schematic representation of the principal components of the polarizabilities.

If α_l and α_t are the principal polarisabilities of the molecule referred to its own principal axes, the average z component of the polarisability per unit volume in the nematic phase can be written as

$$\alpha_z = \alpha_l \langle \cos^2 \theta \rangle + \alpha_t \langle \sin^2 \theta \rangle, \quad (1.4)$$

Using equations (1.3) and (1.4) we get

$$\alpha_z = \left(\bar{\alpha} + \frac{2}{3} \Delta\alpha_0 S \right). \quad (1.5)$$

Similarly

$$\alpha_x = \alpha_y = \left(\bar{\alpha} - \frac{1}{3} \Delta\alpha_0 S \right), \quad (1.6)$$

where $\bar{\alpha} = \frac{\alpha_l + 2\alpha_t}{3}$ and $\Delta\alpha_0 = \alpha_l - \alpha_t$, is the anisotropy of polarisability of a perfectly oriented medium. The absolute value of the order parameter is obtained as

$$S = \frac{(\alpha_z - \alpha_x)}{(\alpha_l - \alpha_t)} = \frac{\Delta\alpha}{\Delta\alpha_0}. \quad (1.7)$$

1.2.2 Refractive Indices

Refractive index is the property of a material that determines the relative speed of light in the material. In the case of liquid crystals, the speed of light for polarisation parallel to the director is different from that for the perpendicular direction. The uniaxial nematic phase has two principal refractive indices called n_e and n_o . The suffixes 'e' and 'o' stand for extraordinary and ordinary rays respectively. For a nematic, $n_e = n_{\parallel}$ and $n_o = n_{\perp}$, where the parallel and perpendicular directions are defined in relation to the director as shown in Fig.(1.4). The birefringence is given by

$$\Delta n = n_e - n_o, \quad (1.8)$$

which is positive and typically varies from 0.01 to 0.2. The relation between the polarisability anisotropy ($\Delta\alpha$) and the birefringence Δn is complicated due to the local field corrections. However, Δn data can directly be used to calculate the approximate order parameter S of nematic liquid crystals using the relation [3,4]

$$S \approx \frac{\Delta n}{\Delta n_o}, \quad (1.9)$$

where Δn_o is the birefringence in the fully aligned state. This approximation is highly justifiable if Δn is very small.

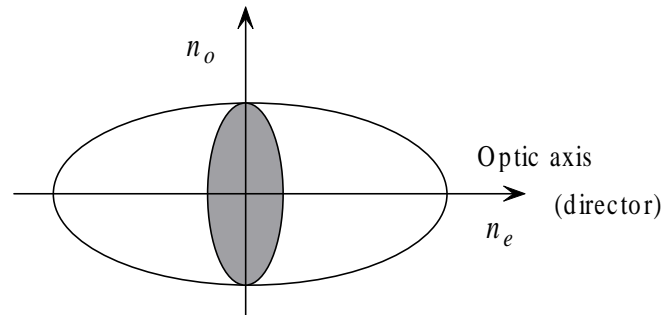

Figure 1.4: Optical indicatrix.

1.2.3 Curvature Elasticity

Because of the fluid nature of nematic liquid crystals, in a deformed medium, the orientation of the molecules varies continuously in space. Any deformation is composed of three basic curvature deformations. They are called splay, twist and bend deformations. Each of these deformations costs positive energy. In Fig.(1.5) the three deformations and the corresponding mathematical terms are shown. The elastic free energy density is given by [2,3]

$$F_d = \frac{1}{2} K_1 (\nabla \cdot \hat{n})^2 + \frac{1}{2} K_2 (\hat{n} \cdot \nabla \times \hat{n})^2 + \frac{1}{2} K_3 (\hat{n} \times \nabla \times \hat{n})^2 \quad (1.10)$$

where K_1 , K_2 and K_3 are the splay, twist and bend elastic constants. The typical magnitudes of these constants are $\sim 10^{-7}$ dynes [2].

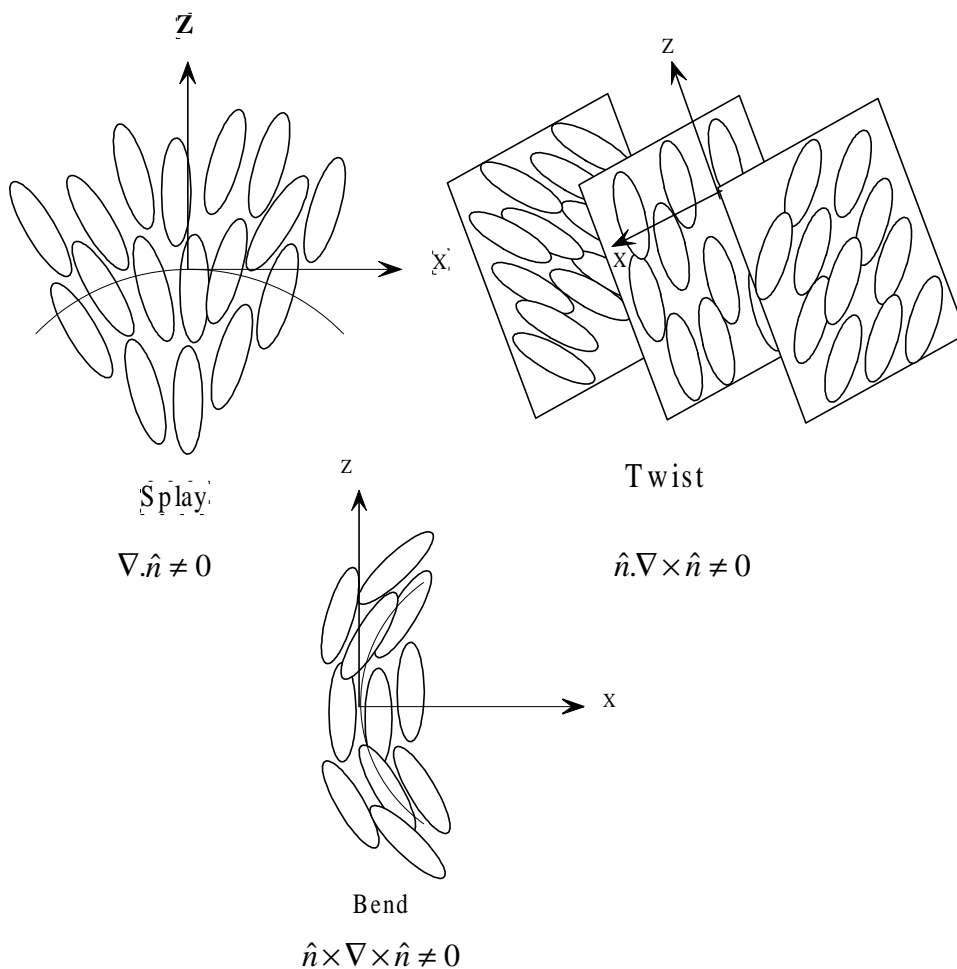

Figure 1.5: A schematic representation of the splay, twist and bend deformations.

1.2.4 Dielectric Constants

Dielectric constant is a measure of the response of material to an external electric field. It depends on the intrinsic properties of the material like distribution of the charges in the molecules as well as the intermolecular interactions. The dielectric constant also depends on the temperature and the frequency of the applied electric field. In liquid crystals with polar molecules in addition to the induced polarisation an orientational polarisation occurs due to the tendency of the permanent dipole moments to orient parallel to the electric field. The orientational polarisation in liquid crystals can contribute significantly to the dielectric constant. On the other hand, in a solid crystal the orientational polarisation does not contribute significantly to the permittivity due to the fixed orientations of the molecules. In liquid crystals, the dielectric constants ϵ_{\parallel} and ϵ_{\perp} are measured with electric field parallel and perpendicular to the director (\hat{n}) respectively (Fig.(1.6)). The dielectric anisotropy is given by $\Delta\epsilon = \epsilon_{\parallel} - \epsilon_{\perp}$.

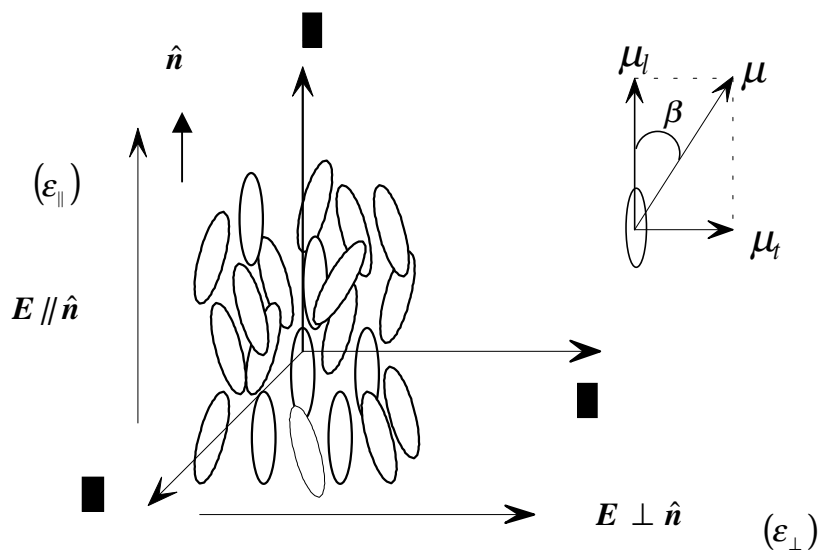

Figure 1.6: Parallel (ϵ_{\parallel}) and perpendicular (ϵ_{\perp}) components of dielectric constants of a nematic. The molecule is assumed to possess a dipole moment μ at an angle β with its long axis giving the longitudinal μ_l and transverse μ_t components. The measuring electric field E can be either parallel ($E \parallel \hat{n}$) or perpendicular ($E \perp \hat{n}$) to the director.

The sign and magnitude of $\Delta\epsilon$ depend upon the polarisabilities and the permanent dipole moments of the molecules. For rod like molecules, the polarisability anisotropy ($\Delta\alpha$) is always positive. Hence, in the absence of permanent dipolar groups $\Delta\epsilon$ is positive and relatively small. On the other hand, $\Delta\epsilon$ of polar compounds depends upon the sign of the dipolar contribution. It is positive, if the net dipole moment of the molecule makes a small angle with the long axis and is negative if the angle made by the dipolar group is sufficiently large.

Maier and Meier's theory gives the following expressions for the dielectric constants [5]

$$\epsilon_{\parallel} = 1 + 4\pi \frac{N_A \rho h F}{M} \left\{ \bar{\alpha} + \frac{2}{3} \Delta\alpha_0 S + \frac{F\mu^2}{3k_B T} \left[1 - (1 - 3\cos^2 \beta) S \right] \right\} \quad (1.11)$$

$$\epsilon_{\perp} = 1 + 4\pi \frac{N_A \rho h F}{M} \left\{ \bar{\alpha} - \frac{1}{3} \Delta\alpha_0 S + \frac{F\mu^2}{3k_B T} \left[1 + \frac{1}{2} (1 - 3\cos^2 \beta) S \right] \right\} \quad (1.12)$$

where $\Delta\alpha_0 (= \alpha_l - \alpha_t)$, is the anisotropy of polarisability of a perfectly oriented medium, N_A is the Avogadro number, ρ the density, M the molecular weight, $h = \frac{3\bar{\epsilon}}{2\bar{\epsilon} + 1}$, is the cavity field factor and $F = \frac{1}{1 - f\bar{\alpha}}$ where $f = \frac{(\bar{\epsilon} - 1)}{2\pi a^3 (2\bar{\epsilon} + 1)}$ is the reaction field factor for spherical cavity and $\bar{\alpha}$, is the average polarisability. The average dielectric constant can be obtained from equations (1.11) and (1.12) as

$$\bar{\epsilon} = 1 + \frac{4\pi N_A \rho h F}{M} \left(\bar{\alpha} + \frac{F\mu^2}{3K_B T} \right) \quad (1.13)$$

The dielectric anisotropy is given by

$$\Delta\epsilon = (\epsilon_{\parallel} - \epsilon_{\perp}) = 4\pi \frac{N_A \rho h F}{M} \left[\Delta\alpha_0 - F \left(\frac{\mu^2}{2k_B T} \right) (1 - 3\cos^2 \beta) \right] S. \quad (1.14)$$

The relative magnitude of the two terms within the square brackets of equation (1.14) determines the sign of $\Delta\epsilon$. When $\beta < 55^\circ$, the two terms add up and the compound exhibits a strong positive dielectric anisotropy. For $\beta \sim 55^\circ$, the second term vanishes and only $\Delta\alpha$ contributes to $\Delta\epsilon$. For $\beta > 55^\circ$, $\Delta\epsilon > 0$ or < 0 , depending on whether the dipolar

contribution is less or more than the contribution due to polarisability anisotropy. In chapter-II we will discuss the effect of strong electric fields on a nematic liquid crystal exhibiting a large ($\Delta\epsilon \approx -8$, at 20⁰C) negative dielectric anisotropy.

1.2.5 Electrical Conductivity

The electrical conductivity in liquid crystals arises because of the mobility of the residual ionic impurities under the application of electric fields. The density of the ionic impurity is typically $\sim 10^{14}/\text{c.c}$ and the typical conductivity is $\sim 10^{-9} (\Omega\text{-cm})^{-1}$. The conductivity anisotropy is given by [2]

$$\Delta\sigma = \sigma_{\parallel} - \sigma_{\perp} \quad (1.15)$$

where σ_{\parallel} is the conductivity along the director (\hat{n}) and σ_{\perp} that in a perpendicular direction. The sign of $\Delta\sigma$ can be either positive or negative depending on the direction along which the ions can flow easily. Usually, for nematics $\Delta\sigma$ is positive because ions can move more freely along \hat{n} than perpendicular to it. For smectics $\Delta\sigma$ is negative, as it is easier for the ions to flow in the layers than perpendicular to the layers. The current density for electric field acting in an arbitrary direction is given by

$$\vec{J} = \sigma_{\perp} \vec{E} + \Delta\sigma (\hat{n} \cdot \vec{E}) \hat{n}. \quad (1.16)$$

Finite conductivity of the medium causes large heating under strong electric fields. In chapter-II we describe high electric field experiments where the local temperature of the sample under the electric field is measured.

1.2.6 Freedericksz Transition in Nematic Liquid Crystals

Competition between the effects of wall and the effects of external field results in a director distribution that minimises the free energy. The reorienting torque arises through a coupling between an external field and the corresponding susceptibility anisotropy. Suppose a nematic liquid crystal is aligned homogeneously between two glass plates. If the dielectric anisotropy of the medium is positive, and the electric field is applied between two ITO (indium tin oxide) coated glass plates, the molecules tend to align parallel to the field direction after a critical field is reached. The sample is kept between two crossed polarisers and the optic axis is rotated by an angle of 45⁰ with

respect to the polariser. The transition from undeformed to the deformed state occurs at a definite field. This is known as the Freedericksz transition. In the deformed state the molecules make an angle with the glass plates and the transmitted intensity changes. A schematic representation of the director configuration below and above the threshold field is shown in Fig.(1.6). The threshold voltage for the Freedericksz transition is given by [2]

$$V_{th} = \pi \sqrt{\frac{K_1}{\epsilon_0 \Delta \epsilon}} \quad (1.17)$$

where K_1 is the splay elastic constant and $\Delta \epsilon$, the dielectric anisotropy of the medium.

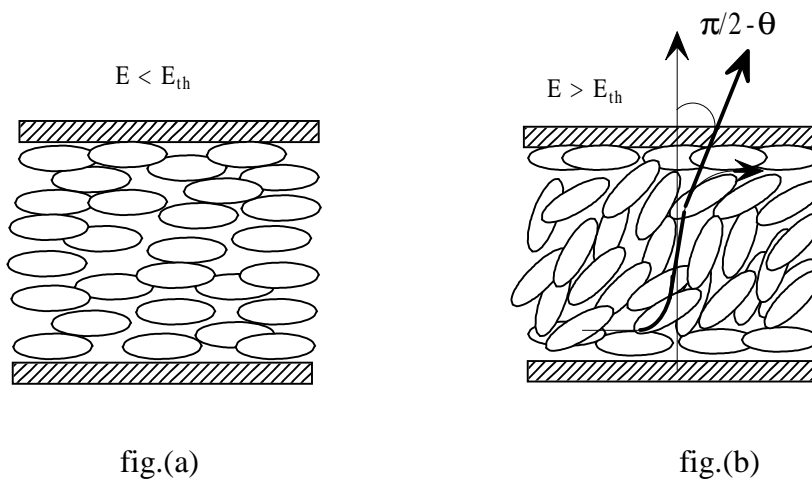

Figure 1.6: Schematic representation of director configuration is shown below and above the threshold field in figures (a) and (b) respectively.

1.3 Chirality

A chiral object is mirror asymmetric, that is, it can not be superposed on its mirror image. Objects that are mirror symmetric are called achiral. A simple example of a chiral molecule is that of an organic molecule with a central carbon atom and with four different atoms or functional groups bonded at the vertices of a tetrahedron (Fig.(1.7)). The chemical structure of a chiral molecule is shown in Fig.(1.8).

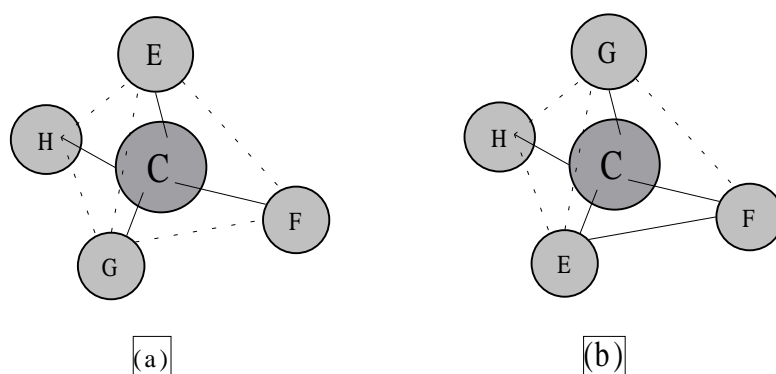
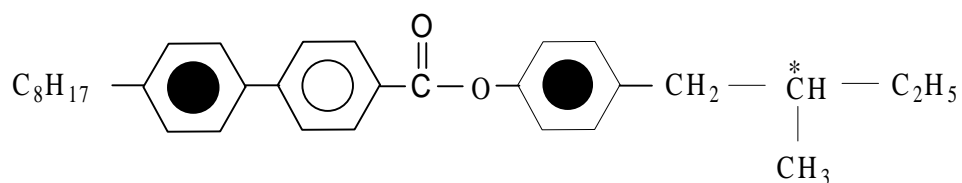

Figure 1.7: Schematic representation of two chiral enantiomers formed by asymmetric substitution of groups to carbon atoms.



Cr- 67- SmI* -70 -SmC* -80.5 -SmA -136.5- N* -138.8 -BP2- 139.7 -BP1 -140.5- I

Figure 1.8: The molecular structure of a chiral compound, which is used in studies described in chapter-V. It exhibits smectic, cholesteric and blue phases. The star indicates the chiral carbon atom and the transition temperatures are given in $^{\circ}\text{C}$.

1.3.1 Cholesteric Liquid Crystals

If chiral molecules are doped in a nematic or the molecules are inherently chiral then a *twisted* or chiral nematic phase (N^*) results. This is known as the cholesteric phase. In this phase the average molecular alignment rotates in a helical fashion as shown in Fig.(1.9). If we take the helical axis to be along the z direction then the components of the director can be written as $n_x = \cos(qz)$, $n_y = \sin(qz)$, $n_z = 0$, where $q = 2\pi/P$, and P is the equilibrium pitch, and the distance between two equivalent planes is $P/2$ because of the apolar nature of \hat{n} .

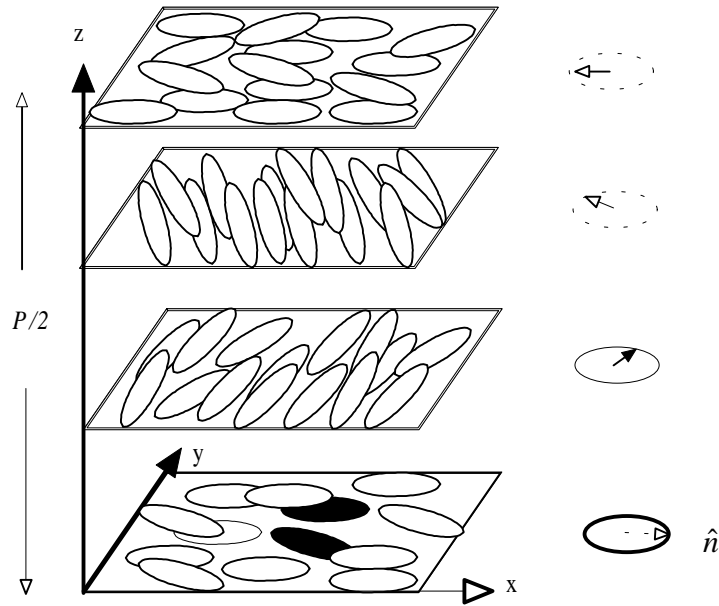

Figure 1.9: Schematic representation of the molecular arrangement in the cholesteric liquid crystalline phase. The short arrows indicate the continuous rotation of the director along the z -axis.

1.3.2 Bragg Reflection

An interesting property exhibited by the cholesteric liquid crystal is the Bragg reflection. When white light is incident on the sample there is a selective reflection of the light wavelength corresponding to the pitch of the cholesteric helix in accordance with the Bragg law. At normal incidence the maximum reflection occurs for the wavelength $\lambda_0 = \bar{n}P$, where \bar{n} is average refractive index and P is the pitch of the cholesteric liquid crystal. The reflected light is circularly polarised having a typical bandwidth $\Delta\lambda$ which depends on Δn is $\sim 200 \text{ \AA}$ [3]. The sense of handedness of the reflected light is the same as that of the incident beam. The pitch depends on the degree of chirality of the molecules or the concentration in case of a nematic doped with chiral materials. The chiral strength of the medium is inversely proportional to the pitch.

1.4 Smectics

In the smectic phases the molecules form layered structures. In addition to the orientational order there is one dimensional density modulation along the layer normal. In the layer the centers of mass of the molecules are random i.e. liquid-like. The one dimensional periodicity along the layer normal gives rise to large thermal fluctuations in the position of the layers [2]. The periodic structure is described by a sinusoidal density wave which is given by

$$\rho = \rho_0 \left\{ 1 + \text{Re} \left(|\psi| e^{i(q_0 z + \phi)} \right) \right\}. \quad (1.18)$$

where z is along the layer normal, ρ_0 is the average density, $|\psi|$ is the amplitude of the density wave, $q_0 (= 2\pi/d)$ the wave vector, ϕ is an arbitrary phase and d is the layer thickness. Depending upon the orientation of the molecules in the layer, smectics can be classified as in the following:

1.4.1 Smectic-A (SmA) Liquid Crystals

In the SmA phase the director \hat{n} is parallel to the layer normal. The structure of the SmA phase is shown schematically in Fig.(1.10).

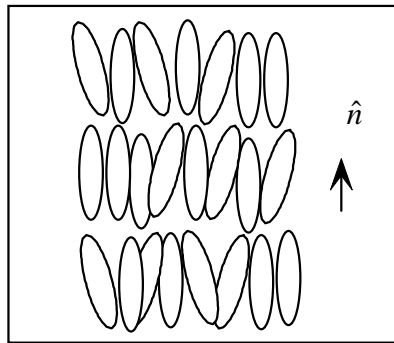

Figure 1.10: Schematic representation of the layered structure of the molecules in the SmA phase.

1.4.2 Smectic-C (SmC) Liquid Crystals

In this phase the molecules are tilted with respect to the layer normal. The structure of the SmC phase is shown schematically in Fig.(1.11).

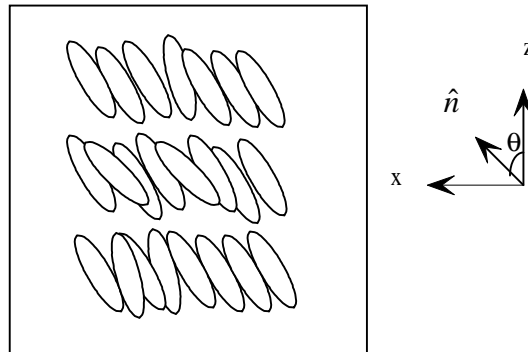

Figure 1.11: Schematic representation of the molecular arrangement in the SmC phase. The molecules are tilted with respect to the layer normal z .

1.4.3 Smectic-C* (SmC*) Liquid Crystals

When the SmC phase is doped with chiral substances or the molecules are optically active, it forms a helical structure. The helix is formed by precession of the tilt direction about an axis perpendicular to the layers with a characteristic pitch as shown in Fig.(1.12).

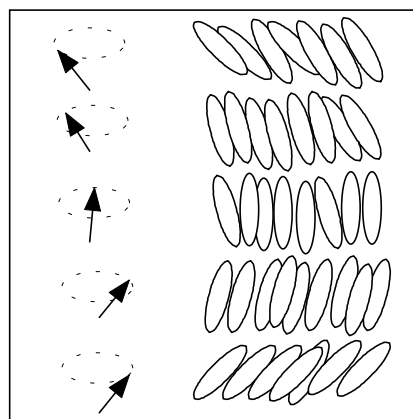

Figure 1.12: Schematic representation of the molecular arrangement in the smectic-C* phase. The tilt direction rotates between successive layers as represented by arrows. The periodicity is usually of the order of a micron.

Depending on the chirality of the molecule, the helix can be either left-handed or right-handed. The symmetry of the SmC^* layers allows them to be transversely polarised hence SmC^* is also referred to as a ferroelectric liquid crystal [6].

1.5 Topological Defects in Liquid Crystals

Topological defect is a defect in an order parameter field that cannot be eliminated by any continuous distortion of the order parameter. Such a defect is characterised by some integer-valued index, such as the winding number. It generally has a core region, where the order is destroyed, and a far field region characterised by a nonvanishing strain [7]. The nematic has line defects called disclinations. A periodic crystal has defects called dislocations in which the phase of the mass density changes by 2π in one circuit around a core. Apart from disclinations, smectic liquid crystals can also exhibit two types of dislocations called *edge* and *screw* dislocations due to the layered structure. The schematic representation of the above two dislocations are shown in Fig.(1.13). Consider smectic layers with layer normal along the z direction. In the presence of dislocations, the change in the layer displacement field \vec{u} , integrated along a closed loop enclosing the

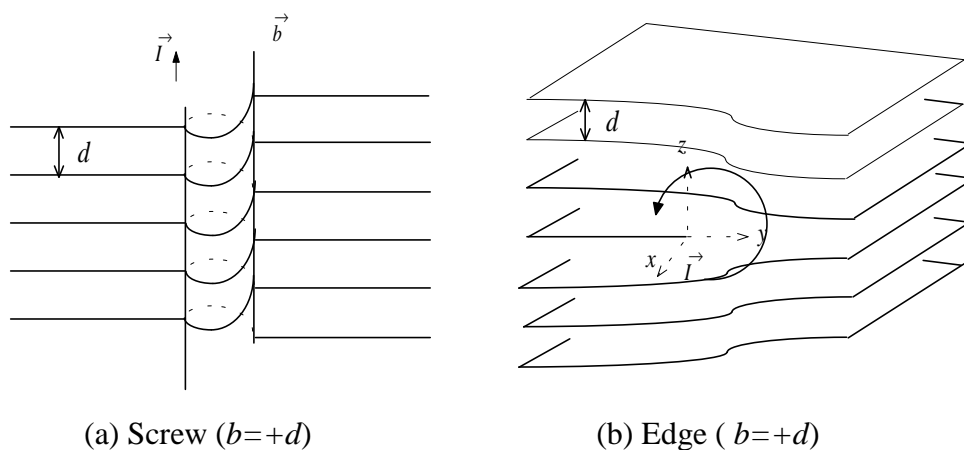

Figure 1.13: (a) Schematic representation of a screw dislocation in the smectic-A phase. Notice that smectic layers rise in going from left to right. (b) edge dislocation (an extra layer is inserted at the edge dislocation line \vec{I}).

dislocation line is given by [4]

$$\oint d\vec{u} = (nd)\hat{z} = \vec{b}, \quad (1.19)$$

where d is the layer spacing, n is an integer and \vec{b} is called the Burgers vector of the dislocation. The nature of the dislocation depends upon the relative orientation of \vec{b} with respect to the dislocation line (\vec{l}). If \vec{b} is parallel to \vec{l} , it is called a screw dislocation. In this case the smectic layers climb up or down by an integral number of layer spacings on going round the dislocation line \vec{l} . If \vec{b} is perpendicular to \vec{l} , it is called an edge dislocation. In this case, a certain number of layers are added or removed from one side of the dislocation line. In Fig.(1.13) we show the schematic diagram of the two types of dislocations in smectic liquid crystals, which are relevant to the discussion in chapters-V and VI.

1.5.1 Twist Grain Boundary (TGB) Liquid Crystals

The twist grain boundary (TGB) phase is the analogue of vortex state in a type-II superconductor under a strong magnetic field. This similarity was pointed out by de Gennes [8]. Renn and Lubensky [9] theoretically predicted the detailed structure of the TGB phase. The TGB_A phase consists of a regular twisted arrangement of SmA blocks separated by grain boundaries made of arrays of screw dislocations. Goodby et al [10] reported the first observation of TGB phase in some highly *chiral* liquid crystals. Depending on the local smectic order, the TGB phases are classified as TGB_A , TGB_C , TGB_C^* etc. A schematic representation of the structure of a TGB_A phase is shown in Fig.(1.14).

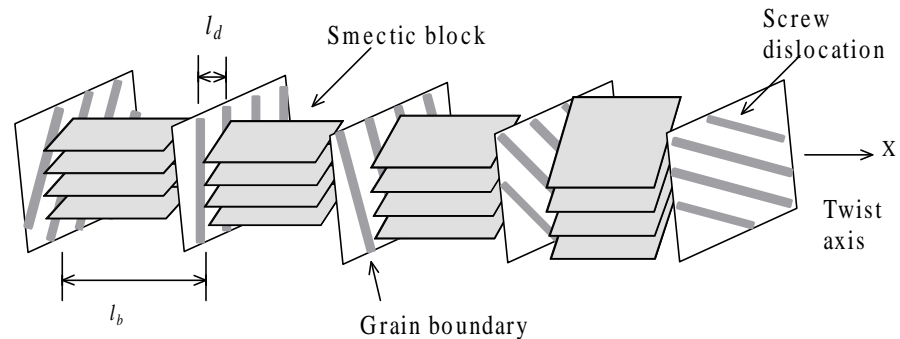

Figure 1.14: Schematic representation of the structure of a TGB_A phase. l_b is the distance between two grain boundaries and l_d is the distance between two dislocations.

In 1997, Pramod et al [11] reported a new defect phase called Undulating Twist Grain Boundary ($UTGB_C^*$) phase with SmC^* -like block structure in a binary mixture of a *chiral* and a *nonchiral* compound. A schematic representation of the structure of $UTGB_C^*$ phase is shown in Fig.(1.15). Besides having a helical structure within the smectic blocks, this phase is also characterized by a two-dimensional modulation of the grain boundaries orthogonal to the TGB twist axis. This structure has twist deformation along three mutually orthogonal directions.

In chapter-V we present some experimental results on mixtures that exhibit TGB_A and $UTGB_C^*$ phases with increasing concentration of the nonchiral compound. In chapter-VI we present our theoretical results on the structural parameters of the TGB_A phase.

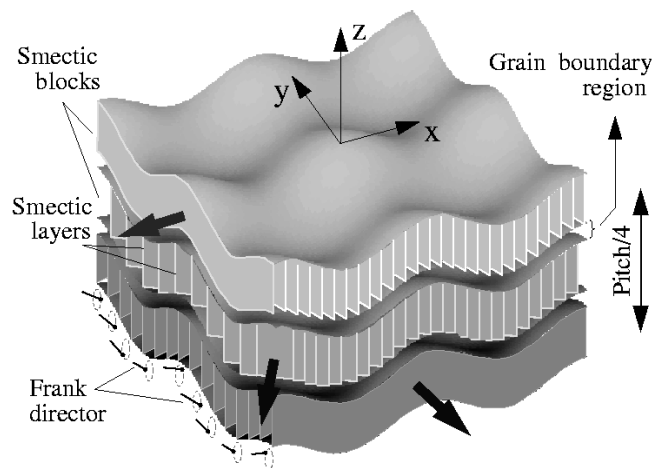

Figure 1.15: Schematic representation of the structure of the $UTGB_C^*$ phase. The smectic layer normals (large arrows) rotate from block to block. Within each block the Frank director precesses along the layer normal direction as represented by the nails [adapted from ref.(7)].

1.6 Preparation of Cell

We use indium tin oxide (ITO) coated glass plates to make cells. The procedure is as follows: ITO coated glass plates are etched by photolithographic technique to get the

desired electrode patterns (see Fig.(1.16)). We use polyimide for planar and ODSE (octadecyl triethoxy silane) for homeotropic alignment of the molecules as discussed later. Mylar spacers or glass beads are used with epoxy glue to maintain uniform thickness between the glass plates. The adhesive is cured by keeping the cells in an oven at a temperature of 150 °C for 90 minutes. The electrical connections to the cells are made by soldering copper wires using an ultrasonic gun.

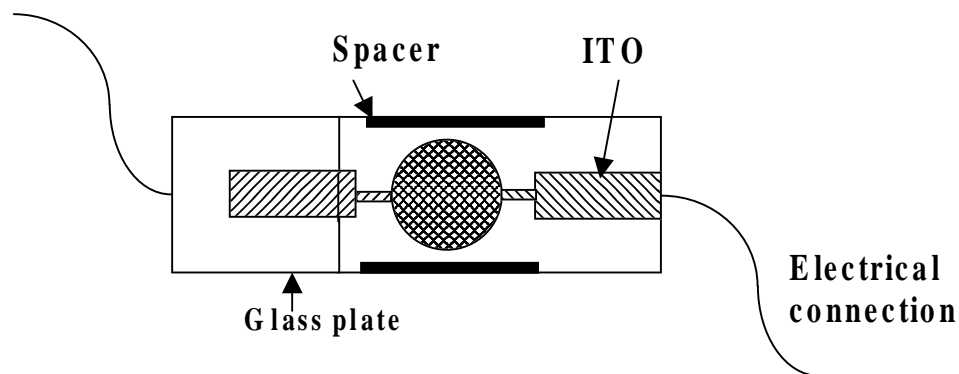

Figure 1.16: Schematic representation of a liquid crystal cell. The black portions indicate the spacers and the circular region is the effective electrode area.

1.6.1 Cell Thickness Measurement

The thickness of the empty cell is measured by using an interferometric technique. The schematic diagram of the setup is shown in Fig.(1.17). A white light source is kept at the focal length of the lens L_1 so that parallel rays pass through the beam splitter BS. The light reflected by the two internal surfaces of the cell interferes and the interference fringes are observed at the field of view of a constant deviation spectrometer (CDS). If λ_m corresponds to the wavelength of the m^{th} dark fringe and λ_n corresponds to the n^{th} dark fringe measured by using the spectrometer, the thickness of the air gap between two glass plates can be calculated by using the formula

$$d = \frac{\lambda_m \times \lambda_n}{\lambda_m - \lambda_n} \times \frac{n - m}{2} \quad (1.20)$$

where d is the cell thickness.

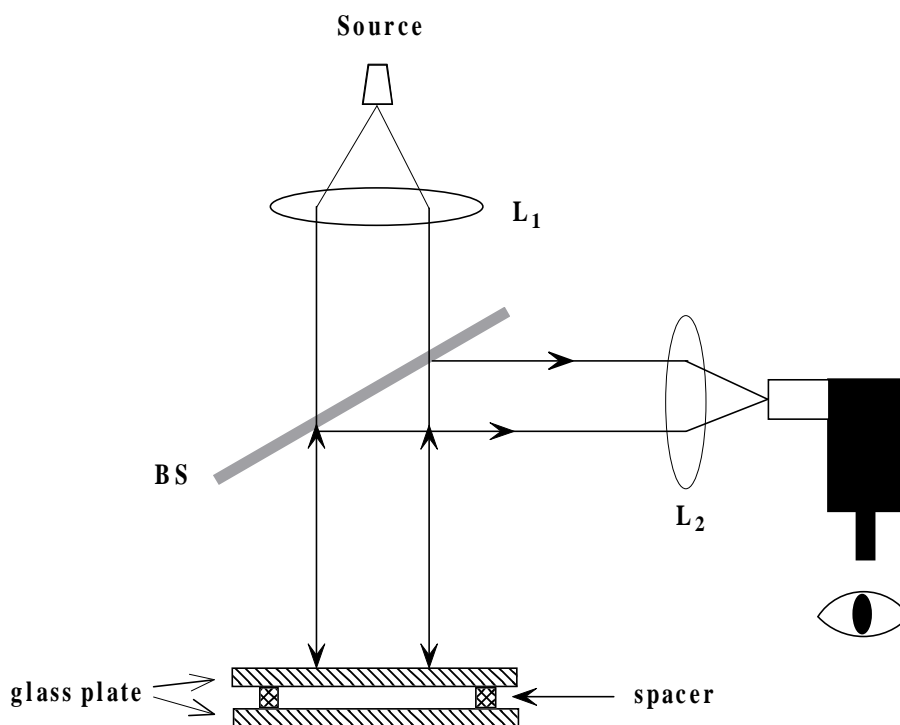

Figure 1.17: Schematic diagram of the setup for measuring the empty cell thickness. BS: Beam splitter, L_1 and L_2 Lenses, CDS: Constant deviation spectrometer.

We have also used an Ocean Optics miniature fiber optic spectrometer (model, S2000) to measure the empty cell thickness. A schematic representation of the setup is shown in Fig.(1.18). The beam diameter of the light is narrow ($\sim 2\text{mm}$) and we can precisely measure the cell thickness at various positions. This spectrometer can be used in transmission and reflection modes. We will discuss its use in studying the reflective spectrum from a cholesteric liquid crystal in chapter-V.

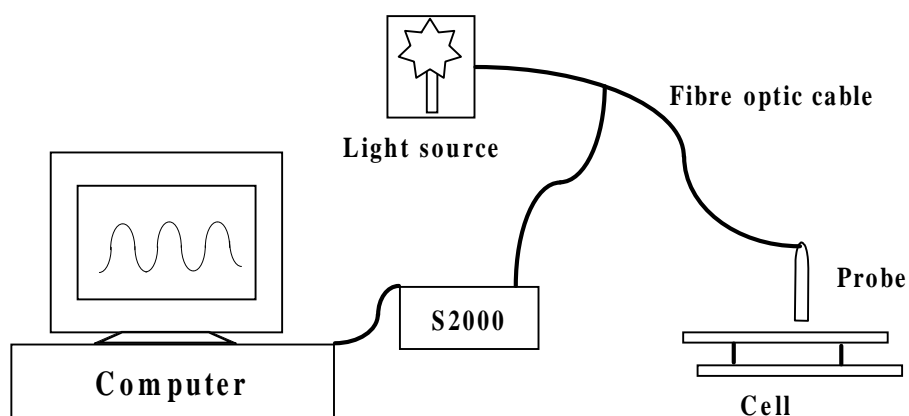

Figure 1.18: A schematic diagram of the experimental setup for the cell thickness measurement using Ocean Optics spectrometer (model S2000).

1.6.2 Alignment of Liquid Crystals

In order to perform measurements of physical properties, the director should be aligned in a specific direction in the cell. Generally the director is aligned either parallel or perpendicular to the plane of the glass substrate.

Homogeneous or Planar Alignment: The molecules can be aligned parallel to the plane of the glass plates by coating the glass plates with polyimide and rubbing unidirectionally. This geometry is called homogeneous or planar geometry. The rubbing on polyimide generates micro-grooves along which the long axes of the molecules are aligned. In the case of uniaxial nematic liquid crystal the optic axis will be

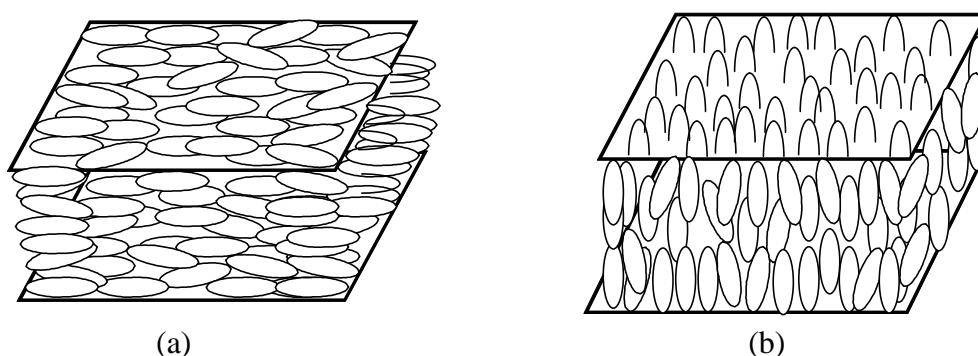

Figure 1.19: Schematic representation of (a) homogeneous and (b) homeotropic alignment of molecules.

along the rubbing direction. Another way to obtain homogeneous alignment is by evaporating SiO in vacuum on glass plate at a grazing angle of incidence of 30^0 [2].

Homeotropic Alignment: The molecules can be aligned perpendicular to the plane of the glass plate by coating a surfactant on to the glass plate. This geometry is called homeotropic geometry. The surfactant (ODSE (octaldecyl triethoxy silane)) has a polar head group and a long alkyl chain. The head groups sit on the glass plate and the chains stay perpendicular to the plane of the glass plate and give rise to the perpendicular alignment of the long axes of the molecules.

References

- [1] W. H. de Jeu, "Physical properties of liquid crystals.," 2nd ed. (Cambridge University Press, 1992).
- [2] P. G. de Gennes and J. Prost, "The physics of liquid crystals.," 2nd ed. (Clarendon, Oxford, 1993).
- [3] S. Chandrasekhar, "Liquid crystals.," 2nd ed. (Cambridge University Press, 1992).
- [4] D. A. Dunmur, A. Fukuda and G. R. Luckhurst, "Liquid Crystals: Nematics.," (An Inspec Publication).
- [5] W. Maier and G. Meier, Z. Naturforsch **16a**, 262 (1961).
- [6] R. B. Meyer, L. Liebert, L. Strzelecki and P. Keller, "Ferroelectric liquid crystals.," J. de Phys. Lett., **36**, 69 (1975)
- [7] P. M. Chaikin and T. C. Lubensky, "Principle of condensed matter physics.," (Cambridge University Press, 1995).

[8] P. G. de Gennes, "An analogy between superconductors and smectics.," *Solid State Commun.* **10**, 753 (1972).

[9] S. R. Renn and T. C. Lubensky, "Abrikosov dislocation lattice in a model of the cholesteric to smectic-A transition.," *Phys. Rev. A* , **38**, 2132 (1988).

[10] J. W. Goodby, M. A. Waugh, S. M. Stein, E. Chin and R. Pindak, "Characterisation of a new helical smectic liquid crystal.," *Nature* **337**, 449 (1998).

[11] P. A. Pramod, R. Pratibha, and N. V. Madhusudana, "A three dimensionally modulated structure in a chiral smectic-C liquid crystal.," *Current Science* **73**, 9 (1997).