

Chapter 2

Instrumentation for dynamic light scattering studies

2.1 Introduction

Dynamic Light Scattering (DLS) is a fast technique to study dynamics in soft condensed matter systems. The method involves performing on-line autocorrelation of the intensity fluctuations of the light scattered from the sample. To obtain reproducible results from DLS experiments it is necessary to have the source and detector free of self correlations. Also, capability of high speed signal processing to perform on-line autocorrelation and a means of maintaining the steady sample temperature.

2.2 Basic components and their characteristics

The main components of a DLS set up are shown in figure(2.1). Here the prepamplifier and the discriminator were specially designed, fabricated and tested in the laboratory by us. The digital correlator was purchased from Malvern Instruments Ltd., UK. The important characteristics of each of the components in the context of DLS experiments are discussed in the following subsections.

2.2.1 The light source

Lasers have properties that make them ideal as light sources in DLS experiments. Some of the laser parameters that are important in DLS experiments are :

1. **Polarization:** It is important for the laser beam to have a very high

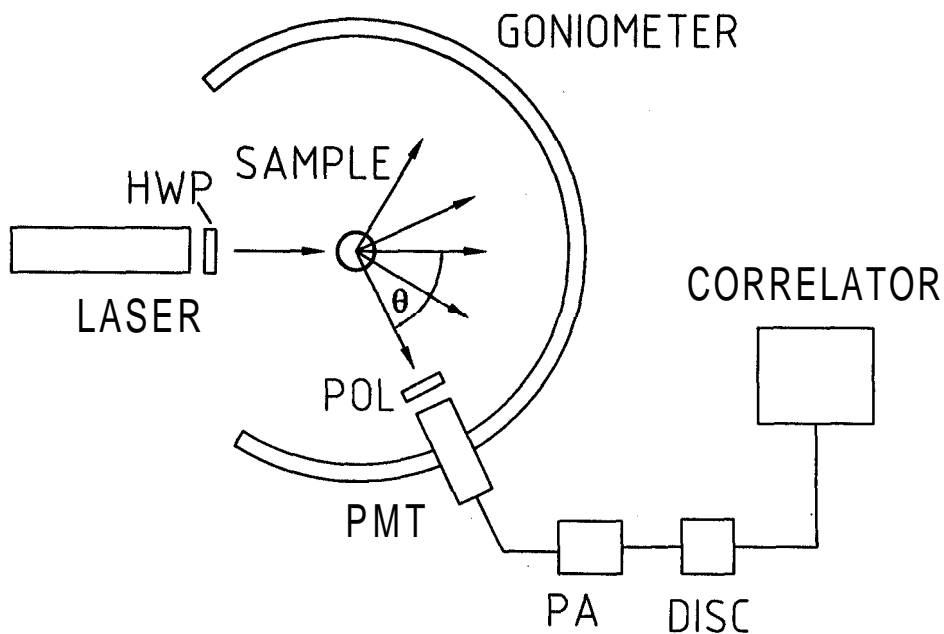

Figure 2.1: Schematic diagram of the basic components of a DLS set up. Light of known polarization from a steady laser source, is passed through a half wave plate (HWP) before it is incident on the sample under investigation. The scattered light is detected by a photomultiplier tube (PMT) whose output is amplified by a pre-amplifier (PA). The polarization of the detected light is selected by a polarizer (POL). The pre-amplifier output is passed on to a discriminator (DISC), for suppressing noise pulses and standardizing the PMT signal pulses. The output of the discriminator is a rate modulated pulse train which is passed on to a correlator for on-line autocorrelation.

degree of linear polarization, especially in the case of DLS from anisotropic media like a liquid crystal. In scattering from liquid crystals, the scattering arrangement determines particular mode of the director fluctuations being sensed which in turn depends on the directions of polarizations of the incident and scattered light.

2. **Wavelength and direction stabilities:** These become crucial in situations where the scattering volume is very small. If the laser beam changes direction with time the beam will no longer illuminate the sample. This will result in no output signal.
3. **Intensity Stability:** Laser intensity fluctuations should be minimal in DLS experiments. One of the reasons why such intensity fluctuations may occur is because of a direct reflection of a part of the laser beam from one of the optical surfaces in the system back into the laser cavity rendering the output unstable. If these intensity fluctuations occur on time scales comparable to the relaxation time scales selected in the DLS experiment, spurious artifacts get introduced in the results [1].

2.2.2 The digital autocorrelator

In our experiments we have used a commercial photon correlator Malvern 4700c. This instrument can be operated in various modes. For example, the instrument can perform autocorrelation, cross-correlations and Variable Time Expansion (VTE) correlations [2]. We have mainly used the correlator to perform autocorrelation of a rate modulated pulse train. The digital autocorrelator calculates the discrete time autocorrelation of any variable $v(t)$ with a delay time $x\tau$

$$G(xT) = \sum_{t=1}^k v(t)v(t - x\tau) \quad (2.1)$$

Where $x=0,1,2,\dots,n$. and τ is the sample time.

The rate modulated pulse train is a representation of the intensity fluctuations sensed by the detector. These pulses randomly arrive at the correlator input stage, where

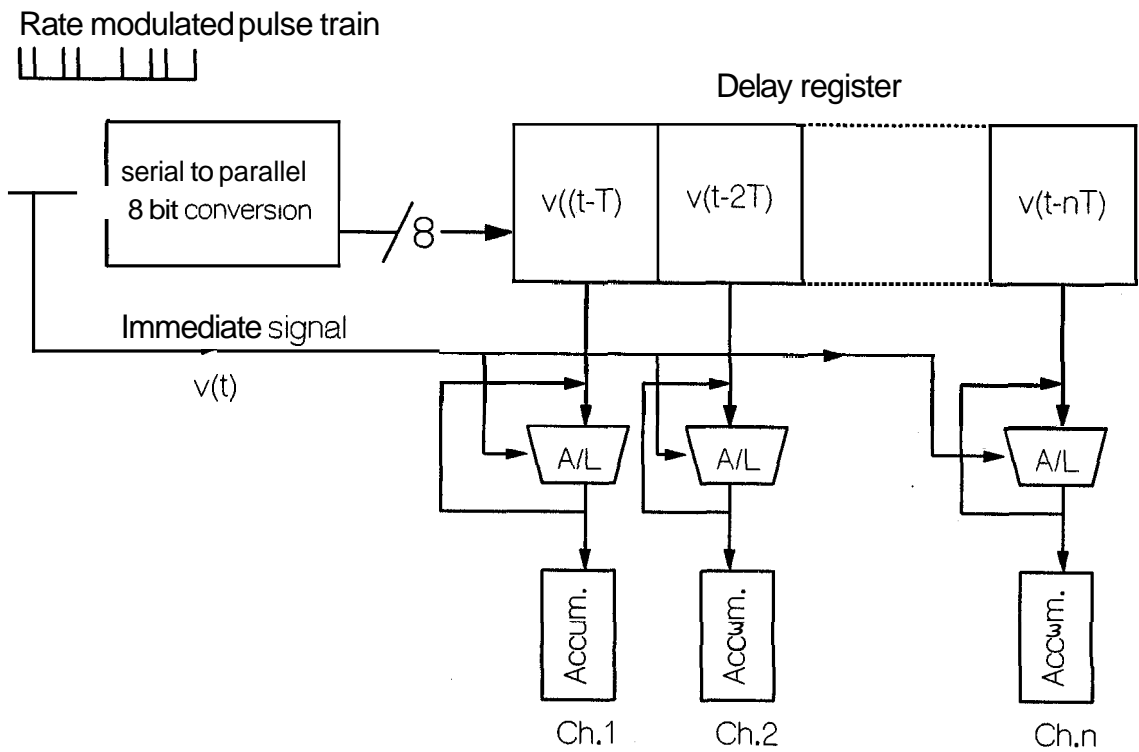

Figure 2.2: Block diagram of autocorrelator.

they are synchronized to a fast basic clock running at 10MHz. Block diagram of an autocorrelator is shown in figure(2.2). This process is called derandomization. The clock speed determines the rate at which the pulse train is sampled for the duration set by the delay time. At the start of each sample a serial to 8-bit parallel conversion process is initiated which results in the number of counts that have arrived in the sample to be represented as an 8 bit number. This 8 bit value is passed down a shift register. Old readings advance along the delay register as new ones enter. The multiplication of the current signal and the delayed version is implemented by successive additions. The incoming pulse train is passed down the immediate path to each add/latch. For every pulse that arrives at the correlator input, the contents of each delay register element is added to the sum of in the corresponding accumulator. The partial sum accumulated per interval is equal to the number of input pulses multiplied by the 8-bit representation held in a particular delay element.

2.2.3 The light detector

In DLS experiments the detector is usually a photomultiplier tube(PMT). When the PMT is operated in the photon counting mode, the output is a rate modulated pulse train representing the fluctuating light intensity falling on the photocathode. After electronic processing and standardization these signals are fed to the autocorrelator.

2.2.4 The pre-amplifier and discriminator

The signals appearing at the PMT output are not only very weak but contaminated with noise like dark pulses and secondary pulses. Before feeding these pulses to the correlator they are passed through an electronic module called an **amplifier-discriminator** which is used to amplify, suppress the noise and standardize the pulses making them suitable for processing by a digital correlator.

2.2.5 The sample oven

In most cases the dynamics occurring in the scattering medium is sensitive to temperature. In any systematic investigation the sample temperature must be held constant

to within ± 0.01 ° C. In suspensions, temperature control is essential to prevent convection currents which might interfere with intensity fluctuations due to Brownian motion. If the sample is held in a non-cylindrical container it may be necessary to do refractive index matching to minimize the difference between the actual and observed scattering angles. In situations where the sample cell is susceptible to pick up mechanical vibrations which have time scales comparable to the relaxation time scales selected in the experiment, spurious results may occur. Care should be taken to effectively damp out such vibrations.

2.3 Fabrication of the pre-amplifier discriminator

The output from a photomultiplier obtained in the absence of input light is called dark current or dark count in photon counting applications. Dark count is considered as noise in the system. Dark count can adversely affect the results of dynamic light scattering experiments by introducing spurious artifacts in the final results. Dark count occurs because of *thermionic emission*. Electrons get thermionically ejected from dynodes midway between the cathode and the anode and start an avalanche of secondary electrons which appears as a pulse at the PMT output. The rate of arrival of the dark pulses is called dark count. One of the ways in which the dark counts can be reduced is by cooling the PMT assembly. But even then dark count will not strictly disappear. PMT signals must be amplified and passed through external circuits for the dark counts to be suppressed. Pulse height discrimination can be used to suppress the dark count. In the following sections we describe the design and testing of a sensitive pre-amplifier for amplifying the PMT output and a discriminator for suppressing the dark count.

2.3.1 Pre-amplifier, design and description

The pre-amplifier unit immediately follows the PMT. The weak PMT pulses of about 100 mV in amplitude and with a width of about 100ns, are fed to the input of the pre-amplifier via a well shielded low loss coaxial cable, An example of the bare PMT

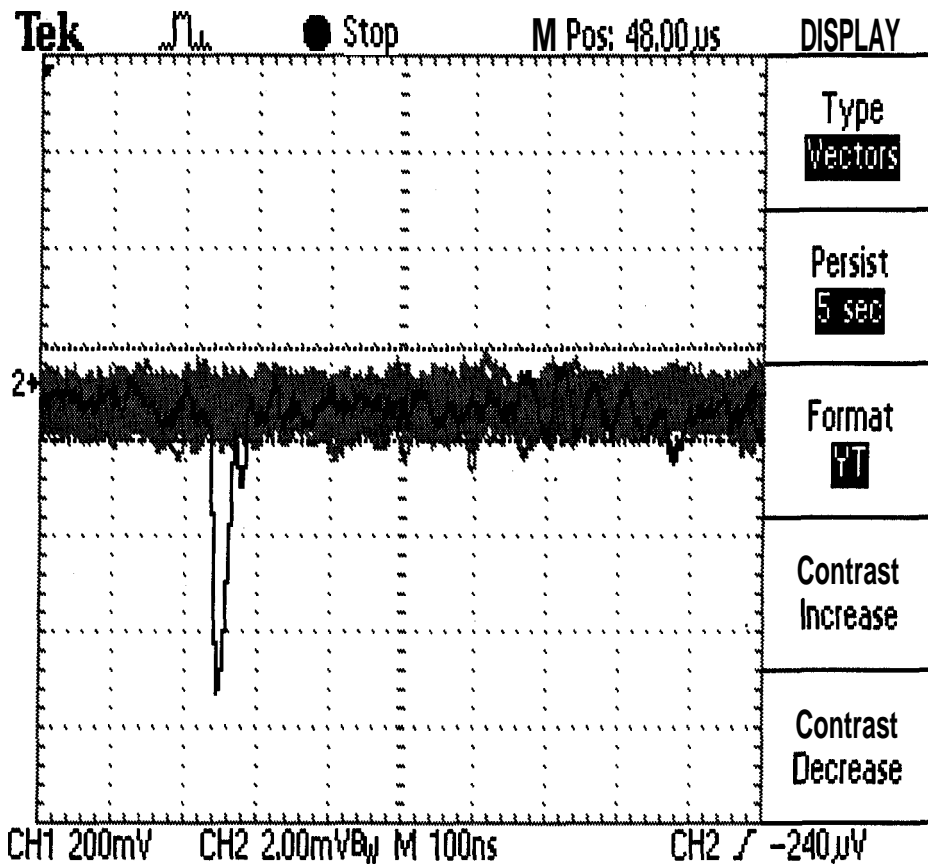

Figure 2.3: An oscilloscope trace showing a typical photopulse at the PMT output. The pulse was captured by operating the oscilloscope in the persistence mode with a persistence time of 5 seconds. Immediately following the photopulse one can see a secondary pulse. Secondary pulses contribute to noise in the signal. Secondary pulses are instabilities that arise either due to very high light input intensities or excessive interdynode potentials. The discriminator dead time can be adjusted to prevent the secondary pulses from triggering outputs.

pulse is shown in figure(2.3).

The circuit diagram of the pre-amplifier constructed by us is shown in figure(2.4). The pre-amplifier is based on the $\mu A733$ which is a two stage differential input, differential output wide band video amplifier. It has a band width of 120 MHz and selectable gain of 10, 100 or 400. The signal from the PMT is fed across a 47K resistor (R_2) to one of the inputs of the $\mu A733$ with the other input grounded via a 500 Ohms resistor (R_3). The amplifier is extremely sensitive to differential inputs. Even a minute DC offset in the input signal can drive the $\mu A733$ into saturation. Thus, extreme care should be taken to remove any DC level in the input signal. To facilitate this, the

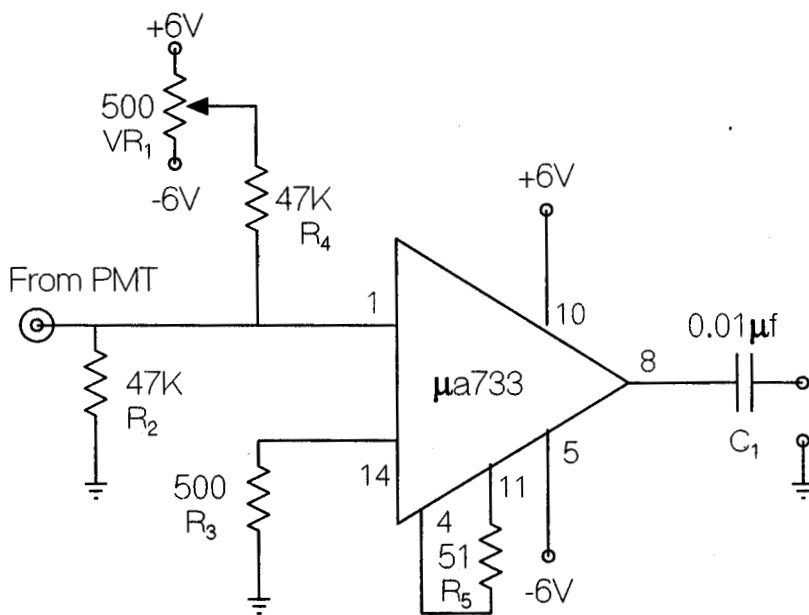

Figure 2.4: The pre-amplifier built by us using the IC $\mu\text{A}733$ wide band video amplifier. The input from the PMT is applied to pin 1 which is level shifted using VR_1 to prevent any **DC** offset in the input from causing amplifier saturation. R_5 is the gain select resistor which, for value of 51 Ohms provides a gain of 400. The output of the pre-amplifier is **AC** coupled via C_1 to the discriminator.

input signal is appropriately level shifted using a 500 Ohms 10 turn potentiometer (VR_1). The $\mu A733$ is operated at its maximum gain of 400. The output signal is AC coupled via a $0.01\mu f$ (C_1) capacitor into the discriminator stage.

2.3.2 Discriminator design and circuit description

The amplitude of the dark pulses will be less than that of a genuine photopulse because it has gone through fewer stages of amplification than the photopulse. The technique of pulse height discrimination can distinguish between these dark pulses and genuine pulses by filtering out pulses lower than a certain amplitude. The task is accomplished by a device called the discriminator. The discriminator is a circuit that generates a single output pulse of well defined width and amplitude for every input pulse exceeding a certain fixed threshold voltage. The action of an ideal discriminator is depicted in figure(2.5).

The pulse height discriminator is implemented using the IC TL710, a high speed low level voltage comparator. The circuit diagram of the discriminator designed by us is shown in figure(2.6). The input signal from the pre-amplifier is first fed into an R-C differentiator formed by R_D and C_D . The leading and edges of the input pulses result in positive and negative spikes at the output of the differentiator.

The decay time of these spikes is solely dependent on the values of R_D and C_D for a given amplitude of the input pulse. An attenuated fraction of this spike is applied to the non-inverting terminal of the TL710 via VR_2 . The discrimination threshold is set by the potentiometer VR_1 and is applied to the pin 3, the inverting terminal of the comparator. The output at pin 7 appears for the duration for which the voltage at non-inverting input exceeds the discrimination threshold applied to inverting input. Since the decay of the spike is controlled by R_D and C_D , in effect the output pulse width is now to a large extent controlled by these external components and the relative heights of threshold and spikes.

Dark pulses will also generate spikes but their heights will be below the threshold set by VR_1 and will not result in an output pulse. The threshold level is optimally

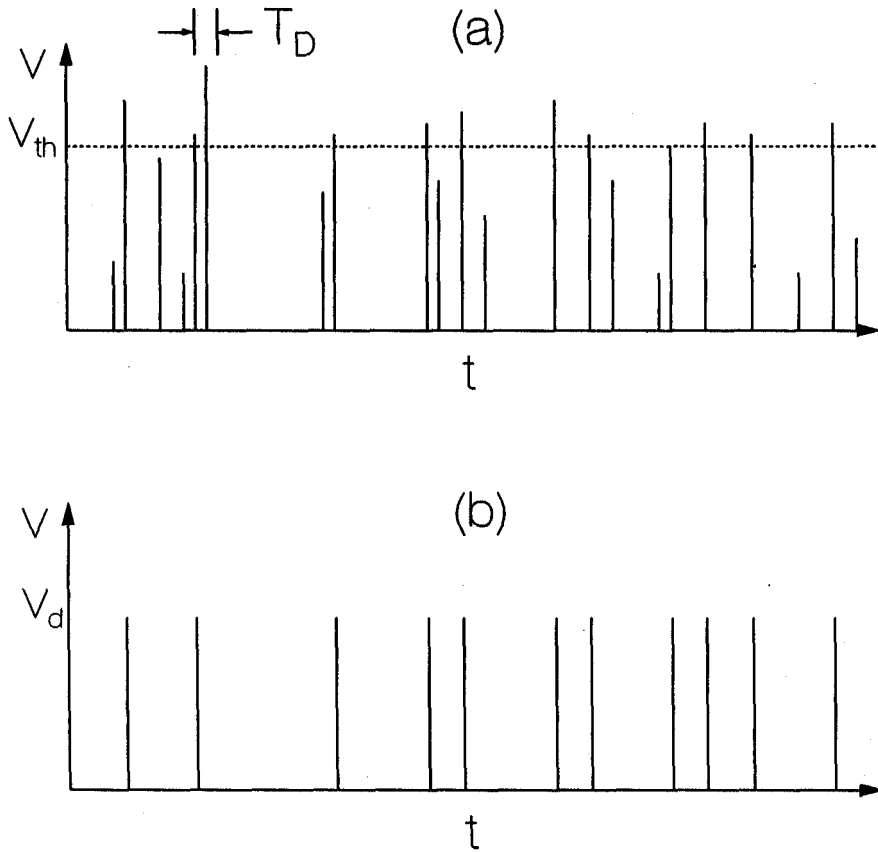

Figure 2.5: Illustrating the action of an ideal discriminator. (a) represents the input to the discriminator which consists of both dark pulses and photopulses. Pulses below a set threshold value V_{th} are suppressed and those above V_{th} are selected, shaped and standardized to result in the output shown in (b). The discriminator introduces a certain dead time T_D during which the circuit is disabled and even pulses above V_{th} cannot trigger an output pulse.

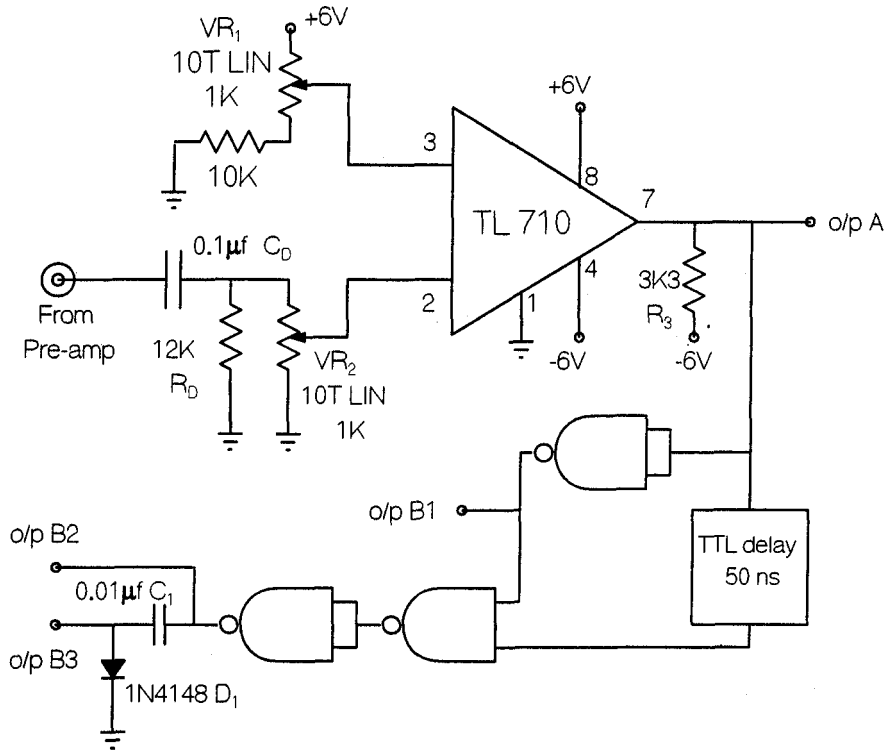

Figure 2.6: The pulse height discriminator fabricated using a TL710 comparator. The input from the pre-amplifier is passed through an RC differentiator formed by R_D and C_D . A fraction of the differentiated output is fed to pin 2 of the TL710. This voltage level is compared with the DC threshold level applied to pin 3 of the TL710 via a 10 turn front panel potentiometer VR_1 . The comparator output is fed to a pulse transition detector and then to correlator via output B3. The outputs A, B1 and B2 are also available in the front panel.

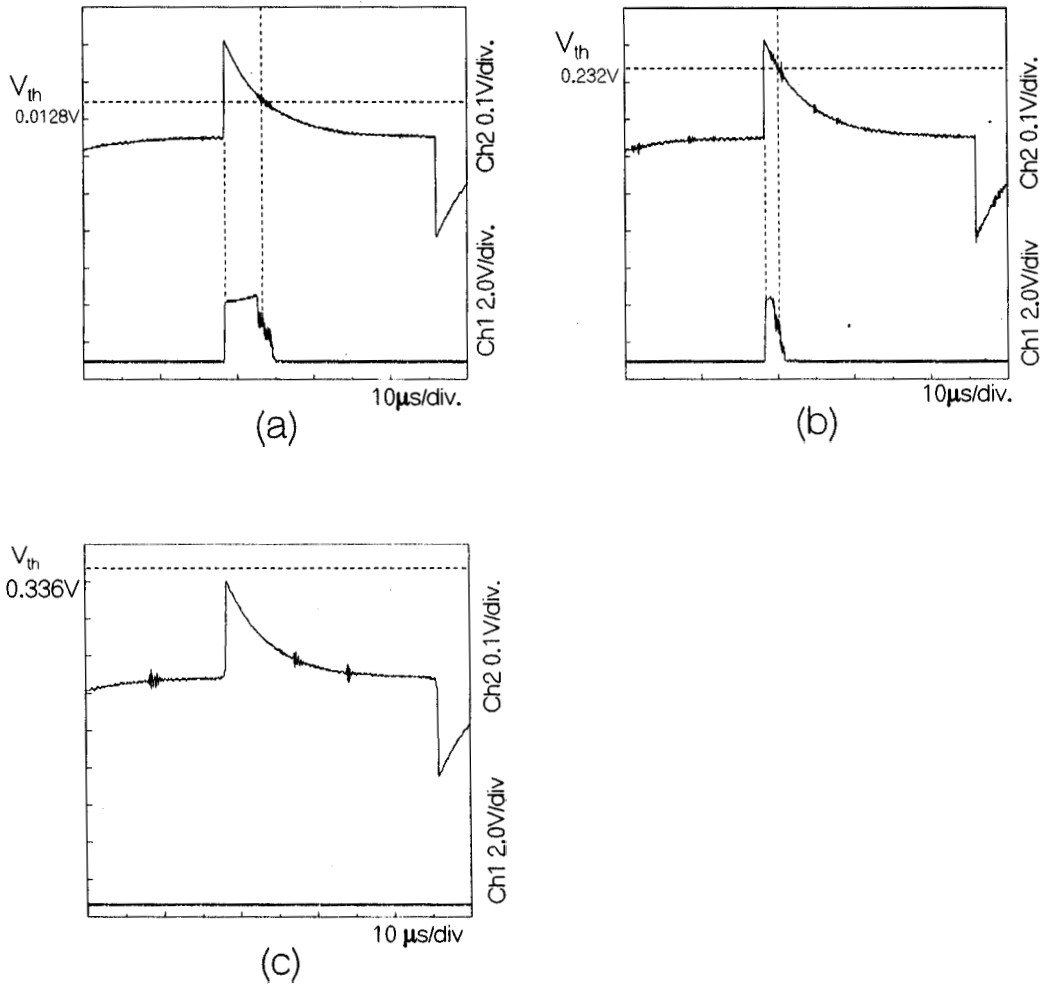

Figure 2.7: Oscilloscope traces illustrating the effect of threshold level on the discriminator output for test pulses obtained from a function generator. In each case, the upper trace shows the waveform at pin 2 of the comparator (obtained from the differentiator) and the horizontal dashed line is the DC threshold applied to pin 3. The lower trace is the waveform at the comparator output A. In (a) the threshold is well below the peak of the spike, resulting in a wide pulse at the output. At a higher threshold the width of the output pulse decreases as shown in (b). In (c) the output completely disappears since the threshold exceeds the spike peak value.

adjusted for maximum sensitivity with a reasonable dark count. The effect of the threshold voltage on the width of the comparator output is shown in figure(2.7) for fixed amplitude input test pulses. It can be seen that the falling edge of the output pulse is distorted by comparator switching noise. The output of the TL710 is further conditioned using a pulse transition detector circuit [3]. The pulse transition detector circuit generates, for every input pulse, an output pulse of a strictly fixed duration determined by a delay line in the circuit.

2.3.3 Testing the amplifier discriminator

The performance of the pre-amplifier discriminator was tested using pulses from a photon counting PMT and from a function generator. The PMT used in our DLS experiments was the ETL 9863, obtained from Electron Tubes Ltd., UK. We checked the count rate dependence on the applied PMT bias voltage under a fixed level of illumination. It was found that the PMT is most sensitive for a bias voltage of -1.775 KV, the manufacturers recommended value is -1.7 KV. The dependence of the count rate on the bias voltage is depicted in figure(2.8). The test set up used for making these measurements and those described in later sections is shown in figure(2.9). The light source is a light emitting diode powered by a stable regulated DC supply. A stack of neutral density filters is used to attenuate the incident intensity before it reaches the pinhole mounted in front of the PMT. The LED, neutral density filters and the PMT are covered with thick black cloth to prevent extraneous light from reaching the PMT. The PMT output pulses are conditioned by pulse pre-amplifier discriminator system and passed on to an oscilloscope and digital multirneter for waveform analysis and pulse counting. The multimeter was interfaced to a PC. We wrote a data acquisition program which performs a 10-point moving average on the count rate readings.

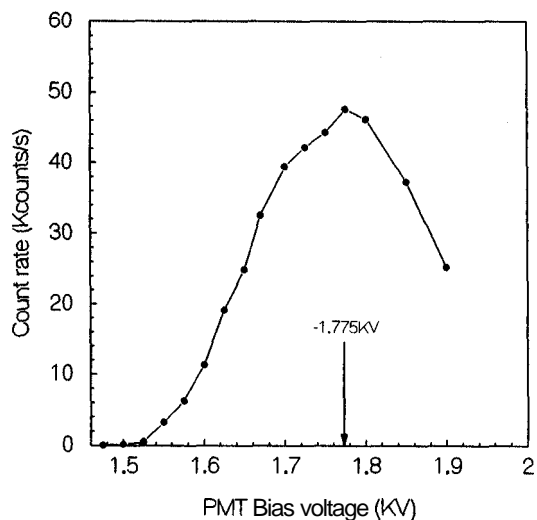

Figure 2.8: The effect of bias voltage on PMT count rate for the ETL 9863 PMT under steady illumination from an LED powered by a regulated power supply. The dip in the count rate at high bias voltages is due to the reduction of secondary emission. The value of the bias voltage is chosen to be that for which the count rate is maximum.

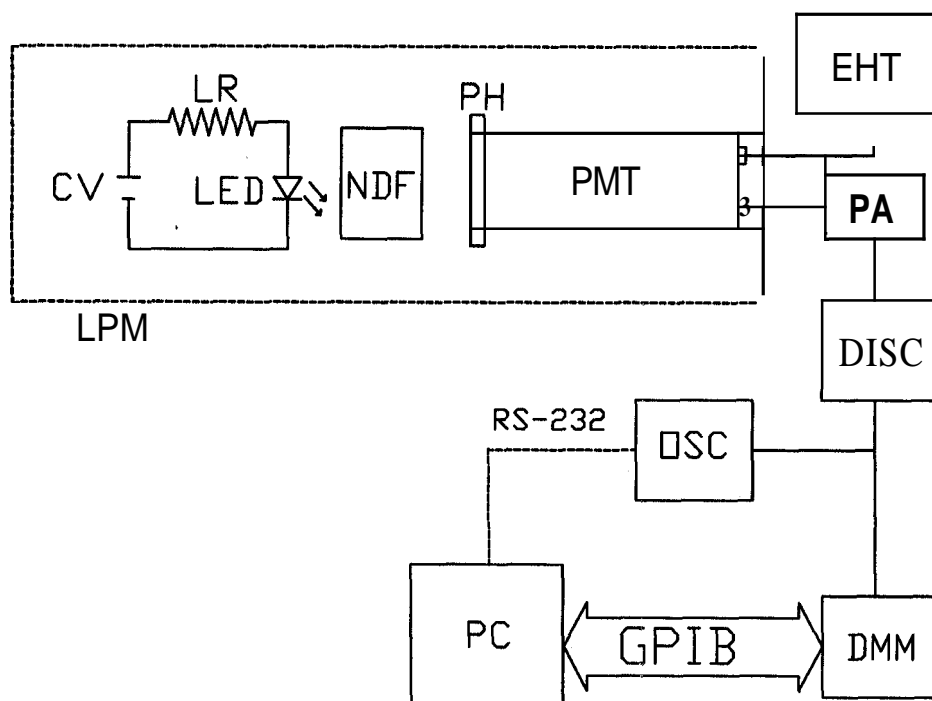

Figure 2.9: The pre-amplifier discriminator test set up. CV, is a regulated power supply, LED the light emitting diode, LR is a current limiting resistor to control the intensity of the LED, NDF is a stack of neutral density filters, PH, a pin hole holder, PMT, the photomultiplier tube and housing, EHT, high voltage PMT, PA, pre-amplifier, DISC discriminator, OSC, digital oscilloscope, DMM, digital multimeter, PC, personal computer, LPM, light proof masking.

2.4 PI temperature control program

The process of control, involves collecting information about the variable involved and then to decide whether the control process is behaving as required or not, and if not to take corrective measures. A very effective means of achieving control is via the Proportional Integral Derivative (PID) control algorithm [4], [5]. Here, we give a brief account of the proportional integral (PI) temperature controller designed and fabricated by us for controlling the temperatures of the sample ovens used in our light scattering experiments. Because of the large thermal mass of our ovens and the insensitivity of our samples to initial temperature surges, we did not use derivative control in our system. In the next section we give a brief account of the algorithm implemented in our temperature control program. A more detailed discussion of the use of the PID algorithm for temperature control can be found elsewhere [6].

Figure(2.10) schematically depicts the step response of a temperature controller.

2.4.1 Proportional integral control

Let $T_p(t)$ be the processed value of the temperature and T_{tgt} the target value or the set temperature. The instantaneous value of the difference temperature is given by,

$$\Delta(t) = T_{tgt} - T_p(t) \quad (2.2)$$

If $V(t)$ is the instantaneous voltage applied to the heating elements then,

$$V(t) = P_{gain}\Delta(t) + I_{gain} \int_0^t \Delta(t)dt \quad (2.3)$$

Where P_{gain} and I_{gain} are the proportional and integral constants. On switching on of the power $\Delta(t)$ is large and the time elapsed is small. Thus, in the beginning the contribution of the integral part is small. The dominant term during this early stage is the proportional term. As the target temperature is approached, $\Delta(t) \rightarrow 0$ and the proportional contribution falls drastically. The time integral of $\Delta(t)$ approaches a constant value which is related to the steady state value of the power supplied to the heater to maintain it at the target temperature. In the steady state, the integral term

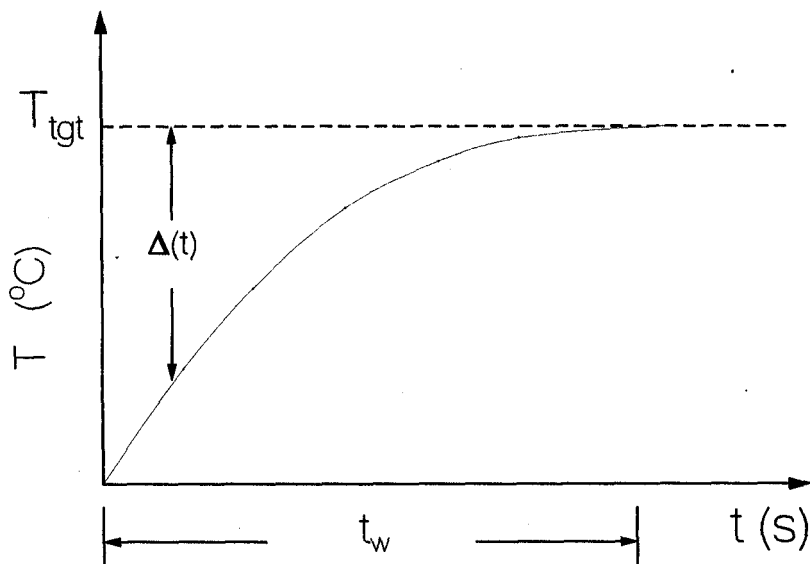

Figure 2.10: The step response of a near ideal temperature controller. The oven temperature is plotted against time. The solid line represents the processed value, T_p and the dashed line is the target temperature, T_{tgt} . $\Delta(t)$ is the instantaneous temperature difference between T_{tgt} and T_p . The time taken for the oven to reach T_{tgt} is called the "warm-up time" t_w .

dominates and has a value corresponding to the difference between the area under the 'dashed' horizontal line and the straight line shown in figure(2.10). The warm up time, t_w and the stability of the system at the target temperature are determined by the numerical values of A and B. In literature, there are many systematic methods of determining the optimum values of these constants depending on system parameters.

2.4.2 Features of the control program

The PI temperature control algorithm was implemented in an interactive C program. A digital multimeter(Keithly 2001) was used to perform a 4-probe RTD measurement to sense the oven temperature and a programmable power supply (Aplab 9712 P) to provide power to the heater. The multimeter used in the system is equipped with a 10 channel scanner card which enables one to make sequential measurements of different quantities. While two channels were dedicated to the oven temperature measurement another channel was used to monitor the PMT count rate from the TTL(Transistor Transistor Logic) output of the discriminator. The count rate is averaged over at least 10 discrete sets. A 10-point moving average (implemented using a FIFO linked list stack) was performed on-line over the count rate readings in the program. The PI controller was interfaced to a PC using a standard GPIB card. The ovens built by us for our light scattering experiments had a large thermal capacity and hence long response times. This allows us to use temperature sampling intervals of 2 seconds and still achieve good control. A control band of width 0.2 °C is used. Whenever the process temperature is outside this range, integral control is disabled. When the band is exceeded on the higher temperature side, the temperature sampling interval is doubled so that the integral term does not become negative. The possibility of the integral term becoming negative exists because the cooling rate of the ovens used in our experiments is very slow. In the event of a "hot-start", that is when the oven temperature is greater than the target temperature at the beginning, the integral term starts with a negative value and the system goes out of control. To prevent this possibility, the steady state values for the integral term at various temperatures

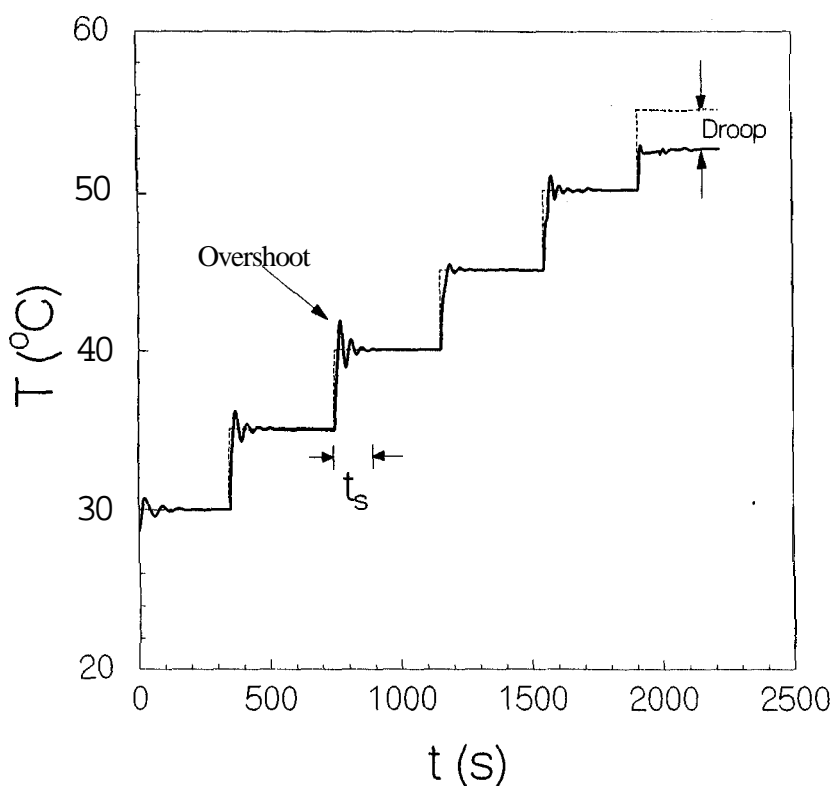

Figure 2.11: The step response of a typical PI controller. The dashed lines show the set value and the continuous line shows the processed value of the temperature. t_s is the settling time over which the temperature oscillates about the set value before settling down to it. The overshoot can be reduced by using derivative control. In the example illustrated here the oven temperature is not able to attain the set value of 56 °C. This is because the power supply is not able to supply enough power to the heater to compensate for the radiation losses from the oven. The difference between this saturated value and the set value is called the droop.

were obtained for the oven used and the integral term is reset to one of these values whenever it becomes negative. A typical heating and step response curve obtained for the PI temperature controller used in our DLS experiments is shown in figure(2.11). For the cooling cycle also a step response curve has been obtained.

The PI temperature controller interfaced to a PC, the pre-amplifier discriminator for the digital correlator and other instrumentation fabricated in the laboratory have been used in the experiments described in chapters 3, 4 and 6.

Bibliography

- [1] R. G. W. Brown and A. E. Smart. Applied Optics, **36**, 7480, (1997).
- [2] H. Z. Cummins and E. R. Pike, editors. Photon Correlation and Light Beating Spectroscopy. Plenum Press, New York, (1974).
- [3] Thomas Floyd. Digital Fundamentals. Universal Book Stall, New Delhi, (1994).
- [4] David J. Powell, Gene F. Franklin and Michael Workman. Digital Control of Dynamic Systems, 3rd ed., Addison-Wesley, Melno Park, (1998).
- [5] Olle Elgard. Control Systems Theory. McGraw Hill, New York, (1997).
- [6] E.M. Forgan. Cryogenics, April (1974)