

Processing of materials in space*

S RAMASESHAN**

Materials Science Division, National Aeronautical Laboratory, Bangalore 560 017

Abstract. This paper reviews briefly many aspects concerning the processing of materials in space. Under micro-gravity conditions many phenomena like convection, liquid flow, etc., are profoundly affected and surface tension forces may take over in some of the heat transfer processes. There are many advantages in studying the various materials processing techniques like electrophoresis, crystal growth, liquid phase miscibility gap and in preparing eutectic alloys, magnetic materials and composites under space conditions. Some of the recent results of such space experiments are presented. The physics of the molecular shield used for reducing the pressures at altitudes of 200 or 300 km by 5 orders of magnitude is discussed. The article concludes with a description of the space shuttle facility and some possible experiments that may be done on it.

1. Introduction

In this article I shall briefly deal with experiences that scientists have had in the processing of materials in space, i.e., in the environment that exists in and around satellites and space vehicles.

Why is there this excitement about the processing of materials in space? We know that when an object is in orbit the inertial forces balance out the gravitational forces so that the net gravitational field is nearly zero. Convection currents in a liquid are caused by acceleration forces acting on density differences. Convection cannot exist if the net acceleration is zero. When convection is considered deleterious in any process there would be some advantage in carrying it out in space. Convection is, however, not always harmful in the processing of materials.

The acceleration felt in an orbiting satellite is *never* exactly equal to zero. Table 1 gives the approximate magnitudes of the acceleration in a low altitude earth orbiting satellite.

2. Convection

How is convection affected by these small accelerations? Convection arises due to the effect of acceleration on density differences or density gradients. Density gradients are produced by temperature gradients ($\partial T/\partial X$) or concentration gradients ($\partial c/\partial X$). We are not at present considering Brownian motion. The small g values shown in table 1 are capable of driving convection currents. To find out the nature of convection movements, one must first compute the velocity of the

* The article is based on a lecture given under the ISRO-IISc Joint Education programme.

** Jawaharlal Nehru Fellow.

Table 1. Acceleration values for a low altitude earth orbiting satellites :
($g = 980 \text{ cm/sec}^2$)

Atmosphere drag	$5 \times 10^{-5} \text{ g}$
Centripetal force	$1 \times 10^{-4} \text{ g}$
Gravity gradient	$3 \times 10^{-4} \text{ g}$
Venting thrust	$10^{-4} \text{ g to } 10^{-3} \text{ g}$
Vehicle thrust	$10^{-2} \text{ g to } 8 \text{ g}$
Passive thermal control	$3 \times 10^{-4} \text{ g}$
g jitter due to manoeuvres and vibrations	10^{-3} g

particles of the substance. Convection would be turbulent if the velocity is large and laminar if it is small. Convection affects not only the transport of the material but also the heat transfer characteristics of the system.

The phenomenon of convection can be described in terms of dimensionless parameters. The Grashof number (Gr) is a measure of the relative magnitudes of the buoyancy and viscous forces. It is defined as follows:

$$\text{Gr} = g \frac{d^3}{\nu^2} \frac{\Delta\rho}{\rho} \quad (1)$$

where g is the acceleration due to gravity, $\Delta\rho$ is the difference in density, ρ the reference density, ν the kinematic viscosity ($\nu = \mu/\rho$ where μ is the absolute viscosity) and d is a linear dimension. Grashof number can also be written in terms of the temperature gradient ($\partial T/\partial X$) as follows

$$\text{Gr} = \frac{\beta g (\partial T/\partial X) d^4}{\nu^2} \quad (2)$$

where β is the coefficient of volume expansion which is equal to $1/T$ for gases. In terms of concentration gradient ($\partial c/\partial x$),

$$\text{Gr} = \frac{\alpha g (\partial c/\partial X) d^4}{\nu^2} \quad (3)$$

where α is the concentration densification coefficient. The Grashof number is related to the fluid velocities (u) as follows:

$$\text{If } \text{Gr} > 1, \quad u = (\sqrt{\text{Gr}}) \frac{\nu}{d} = (\beta g \Delta T d) u^2 \quad (4)$$

$$\text{If } \text{Gr} > 1, \quad u = \text{Gr} \frac{\nu}{d} = \frac{\beta g \Delta T d^2}{\nu} \quad (5)$$

The condition for unstable convection is determined by the Rayleigh number which is related to the Grashof number as follows:

$$\text{Ra} = P_r \times \text{Gr} = C_p (\mu/k) \text{Gr}, \quad (6)$$

where P_r is the Prandtl number, C_p the specific heat at constant pressure, μ the absolute viscosity and k the coefficient of thermal conductivity. In other words Rayleigh number can be written explicitly in terms of gravity as follows:

$$\text{Ra} = C_p \frac{\mu}{k} \frac{g \beta (\partial T/\partial X) d^4}{\nu^2} \quad (7)$$

A reduction in g therefore results in a decrease in the value of Gr, the particle velocity and Ra as seen in the equations above. The effect of a low gravity environment is to reduce convection effects.

3. Surface tension forces and convection

There is another force which can drive convection—the surface tension force σ . The Bond number B_0 compares the gravity force with the surface tension force.

$$B_0 = \rho g d^2 / \sigma.$$

When g is large (as on the surface of the earth) surface tension forces are prominent only when the linear dimension (d) is very small. Under micro-gravity condition surface tension forces can take over even for large dimensions.

Surface tension forces can be affected by temperature and concentration gradients. These surface tension gradients can generate conventional convection flows or unstable cellular flows just as gravity induces such flows: Figure 1 summarises the nature of convection under different gravity conditions.

In the last two sections we have presented the basic concepts of convection under micro-gravity conditions. We shall not in this article deal with heat transfer and the methods used for its computations although these are of great importance in the processing of materials in space.

4. Electrophoresis

In biological research it is often necessary to separate pure samples of cells of a single specific type from a mixture of living cells. If the masses, the sizes or the shapes of the cells are different, we can, in theory, effect this separation. Those that differ in mass can be separated by sedimentation or centrifuging; those that differ in size by filtration through membranes having different pore sizes; and those that differ in shape by flow techniques. Living cells usually are fragile and centrifuging or filtration may destroy them. Further many of these cells are so similar that they may not differ much in their masses, sizes or shapes.

An effective method used for the separation of such cells is by electrophoresis. This method uses the fact that (a) living cells have a surface charge, and (b) the quantity of this charge is as unique to each type of cell as its biological function. A mixture of different cells is placed in a glass vessel containing an electrolytic buffer solution whose composition, pH, etc are compatible with the biological vitality of the cell. When an electric potential is applied the cells would move

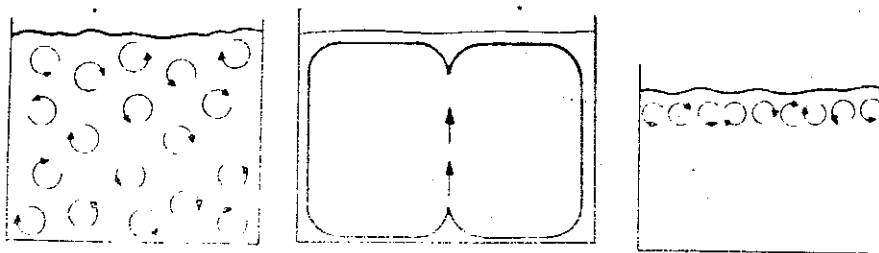

Figure 1. Convection under differing acceleration forces. (a) gravity driven $1g$ (turbulent); (b) gravity driven $10^{-3} g$ (laminar); (c) surface tension driven $10^{-6} g$.

and separate into zones depending on their electrophoretic mobility (figure 2). In normal gravity environment, the density differences between the separated zones and the buffer solution often cause sedimentation. A more serious disturbing effect is caused by the Joule heating of the column, which induces destabilising convection currents. Under micro-gravity conditions these serious limitations can, in theory, be overcome.

A second method of separation is by flow electrophoresis (figure 3) in which the buffer solution is made to flow from left to right and the cell mixture is continuously fed into the flowing liquid. An electric field is applied perpendicular to the direction of flow so that the cells separate laterally in a fan-like manner and are collected through tiny vents.

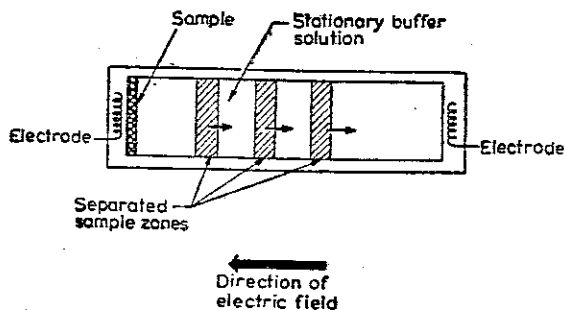

Figure 2. Electrophoresis; cells with differing surface charges move with different velocities and separate into zones. Disturbing effects like sedimentation and convection (due to Joule heating) can be avoided if the experiment is done in space.

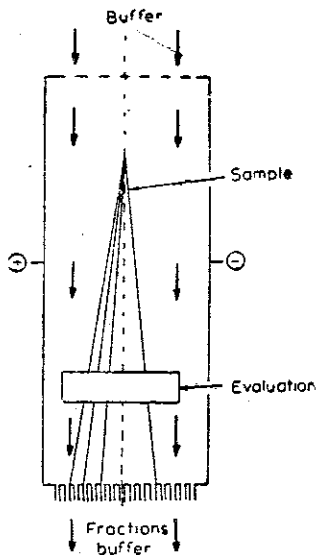

Figure 3. A second type of electrophoretic separation where the applied electric field is perpendicular to the flow direction.

A successful experiment done in space is the separation of cells that produce the enzyme urokinase which is produced in the foetal kidney cells and which can dissolve blood clots. Only 5% of the kidney cortex of the foetal kidney has this capability of producing urokinase and so a separation experiment is essential. The destabilising effects under normal gravity conditions are too large for effective separation and so an experiment was tried out in space. The material was first frozen to maintain the cell viability. The mixture was defrozed and processed electrophoretically in space. The columns were frozen again, stored, brought back to earth and analysed. The results were very encouraging. This is the first of many exciting experiments that are to be done in space in the field of biology.

5. Liquid phase miscibility gap

The liquid phase miscibility gap is a well-known phenomenon in which a single liquid phase separates into two liquid phases of different composition when cooled below a specific temperature. A simple example is the oil-water emulsion. There are a large number of systems which are known to display this liquid phase miscibility gap. Al-Pb, Pb-Au, Bi-Ga, Au-Ga, Cu-Pb are some typical examples in the metallurgical field. To fix our ideas let us consider the Al-Pb system. Between 1.5% and 15% of Pb, a single liquid phase is formed at high temperatures (figure 4). When cooled (1040° C for 15% Pb and 658.5° C for 1.5 Pb) two liquid phases separate out, lead drops form in an aluminium rich-liquid matrix. The particle formation may be due to (a) spinoidal decomposition in which case the phases form instantaneously, giving fine particles distributed homogeneously (b) nucleation and growth, in which case coarser particles form.

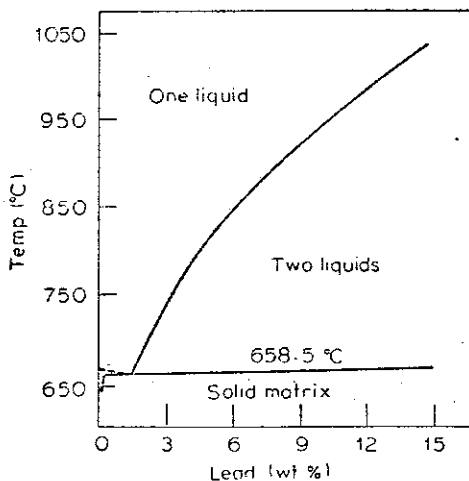

Figure 4. The phase diagram of aluminium-lead system. On crossing the phase boundary the single liquid phase separates into two liquid phases. Liquid lead "precipitates" into an aluminium rich liquid. The agglomeration of the lead drops due to gravity can be avoided if the experiment is performed in space.

Initially Pb is finely dispersed and uniformly distributed in the aluminium-rich matrix. However, lead, being very much denser, begins to sink due to gravity; the particles coalesce and segregation between the matrix and the dispersed phase takes place. The segregation is due to the well-known Stokes migration and the separation (or settling) velocity is

$$V_s = \frac{2r^2 g (\rho_s - \rho_m)}{9\eta_m}$$

where V_s is the terminal settling velocity, ρ_s the density of the particle and ρ_m the density of the matrix, η_m the shear viscosity of the medium and r the radius of the particles. Convection currents also make things more complicated. It is clear that under a micro-gravity environment these effects can be minimised. In fact, if the temperature of the homogeneous suspension is lowered (under micro-gravity environment) one would get a solid with finely dispersed particles. Such systems have many practical uses.

An oil water emulsion segregates in 0.1 sec when $g = 1$ but is stable for at least 10 hr under micro-gravity conditions, i.e., it is at least 10^8 times more stable. It is important for the understanding of these phenomena to know which of the following three processes is the rate determining factor in the coalescence of the particles.

- (i) particle-particle contact due to Brownian movement,
- (ii) the Marangoni effect—i.e., the variation of interfacial energy due to a temperature gradient,
- (iii) the Ostwald ripening—i.e., particle growth due to the overall reduction of the interfacial energy.

It is almost certain that experiments in space would be able to decide the exact nature of the process involved.

If one can produce materials with a uniformly dispersed second phase, it would be the first step towards making many technically important materials. For example Al-Pb with Pb uniformly dispersed would make better bearings. Zn-Pb system would make better electrodes for dry cells.

6. Eutectic alloys

In eutectic solidification, a single liquid phase when cooled forms two *solid* phases of different compositions. Using this phenomenon one can under proper conditions (unidirectional solidification) produce a composite. These are in situ composites in contrast to other composites where the matrix and the reinforcing phase are produced independently and then mixed. When the two phases separate out in eutectic solidification the morphology of the two solids considerably differ. Lamella, fibres or irregular particles may be formed and further the phases may contain a large number of imperfections. When defect-free crystals are formed, the resulting solid is extremely strong. Unfortunately, the exact conditions of formation of a defect-free phase are not known. There is, therefore, a great deal of interest in discovering what these conditions are. One school believes that defects are caused mainly by convection movements and so an improvement in quality may be expected by processing these materials in space. Unless these experiments

are planned carefully, it would be very difficult to interpret the results. Eutectic solidification is a very complex phenomenon, involving homogeneous and heterogeneous nucleation, heat and mass transport coupled with the growth of phases, equilibria of surface tension forces, etc. The exact eutectic composition of these alloys must be known as any deviation from this composition can quite adversely affect the solidification process. The eutectic compositions are usually known only to an accuracy of 5000 ppm. If the composition is not exact there would be supersaturation followed by the rejection of the solute. In gravity environment convection currents set in at the immediate neighbourhood of the solid-liquid interface. However in space where convection is minimal, this natural stabilising effect is not present, leading to the growth of dendrites. The number of parameters involved in this phenomenon is so large that planning an experiment in space for understanding it appears to be difficult. It is a pity that in this field most of the experiments undertaken so far relate to potential application and not to the understanding of this interesting but complex phenomenon.

One fairly successful experiment was when NaF-NaCl eutectic was crystallised in space. NaF fibres were more uniformly spaced and better aligned than those produced on earth. This eutectic is a potential fibre-optic material. Furthermore, the visible and infrared transmission was found to be better than those for the same material made in a 1 g environment.

7. Crystal growth

It is the dream of semi-conductor physicists to grow long, large diameter defect-free crystals. Defects cause malfunctioning of devices, rapid ageing, low reliability and low yields in manufacture. In the case of silicon, large diameter crystals are of advantage in making high current devices, as the current density can be kept low. Further if the diameter becomes larger, the number of single devices required for any application will be smaller. In making integrated circuits the handling cost per chip will be lower if the wafer is large. The yield also increases with diameter of the wafer as most of the imperfections will be on the periphery. For growing good, large crystals, the crucible-free float-zone-refining technique seems to be the best. This consists of moving a molten zone along the length of a polycrystalline rod or a single crystal rod. The purification takes place because of the greater solubility of the impurities in the liquid than in the solid. Under 1 g condition only those substances with a large ratio of surface tension to density can be float-zone-refined because the liquid is held up between the two solid pieces by surface tension forces. Under micro-gravity condition, in theory at least, all substances can be float-zone-refined. Under 1 g condition, diffusion and gravity driven convection mixing predominate while in micro-gravity environment, the diffusion and surface tension driven convection mixing become important. Because of this the transport of heat may become slower affecting the growth rate.

In this technique one must know whether a liquid drop of the material can be supported between two rotating rods—a condition essential for the float-zone method to operate. This experiment has actually been done in space using silicon and the basic feasibility of the float-zone technique in space environment has been established. However, the hydrodynamicist must now consider some rather

important questions, like drop dynamics, shaping and degassing of liquified substances, boundary layers and their properties, capillary forces and stability, the fluid dynamics and heat transfer in the floating zone under micro-gravity conditions.

A fair amount of thought has also gone into the question of furnaces in space. The general conclusions are that from the efficiency and weight point of view, the resistance furnaces and elliptic mirror furnaces appear to be the most acceptable ones. For example in a double elliptic cavity (two ellipsoids with a common focus) with two commercially available tungsten lamps of 400 W placed at the two foci it is possible to attain a temperature of 2100° C at the common focus over a volume of 2 ccs.

8. Other materials

8.1. Magnetic materials

Of some technical importance is the improvement of permanent magnets. The decrease of convection can make processing of such magnetic materials very efficient. For example the elongated single domain magnets (ESD) make use of the shape and crystal anisotropy of single domain particles. These are prepared by electrolytic reduction. Convection induces side-branch dendrite growth making the single domain less effective and less efficient. In space a much better length to diameter ratio can be attained. Table 2 gives the energy product value of some of the magnets and the expected improvements if they are processed in space.

8.2. Composites

The making of composite materials in space appears attractive. Most of the strong fibres like Al_2O_3 , SiC, etc. are lighter compared to the metallic matrix materials. Low gravity condition appears to be of advantage for uniform distribution. Higher volume fractions and more complex geometries can also be attempted. Further it may also be possible to incorporate the fibres with minimum mechanical damage. Unfortunately in space the problem of particle and fibre agglomeration will become

Table 2. Processing magnetic materials in space

	Energy product value when processed	
	on earth	in space
Ferrite	6	8
Elongated single domain	8	45
AlNiCo	15	45
SmCo ₅	25	30
Sm ₂ (Co _{1-x} Fe _x) ₁₇	..	60

very serious. This clumping together of fibres cannot be broken up by stirring alone. These problems are connected with wettability, outgassing, etc. Consequently the question of the elimination of bubbles has to be solved before any significant progress can be expected in this field.

Extremely sophisticated processes are being planned for space experimentation. For example, methods of improving turbine blades by growing them as equiaxed or even as single crystals are being thought of.

9. The molecular shield

A novel idea has been put forward for producing ultra high vacuum over a large volume at altitudes of 200 to 300 km. The atmosphere at these heights has a composition very different from that near the surface of the earth. The ultra-violet radiation from the sun dissociates the gases (particularly oxygen and water). The atmosphere, therefore, consists mainly of atomic oxygen, atomic hydrogen and some helium. While objects at these heights can be very cold when the sun is not shining on them the "temperature" of the atmosphere itself can be as high as 800°K to 1000°K .

This is because there are no significant thermal radiation losses. With some models of the atmosphere the number of atoms that exist at these heights can be calculated and this comes out to be about 10^8 to 10^{10} per cc at 800°K to 1000°K (near the surface of the earth it is about $10^{19}/\text{cc}$). Although the pressure at 200 km is low, the extremely reactive atoms can act as a source of impurity at these heights particularly if one attempts to prepare very pure substances. To overcome this problem a suggestion for using a hemispherical shield 3 to 10 m diameter pulled by a space vehicle (or orbited in space) has been made. The shield will move at a velocity of 8 km/sec and the convex front surface will sweep out the molecules in front. The molecules cannot come behind the shield (figure 5), as the mean free path of the molecules at these heights is about 0.4 km which is very much greater than the shield dimensions. In fact the collision with the shield will be the last collision which the molecules will suffer. The experimental region is the hollow or the concave side of the hemisphere and the density in this region is expected to be 10^3 molecules cm^3 . The sources which contribute to the density are (a) the free stream atmosphere (b) outgassing of the inner side of the shield (c) the gas released by the experiment (d) the gas scattered by the space vehicle (the orbiter) which pulls the shield (e) the gas released by the orbiter itself (outgassing leaks, vents, etc). The effect of each of these can approximately be calculated if one assumes a drifting Maxwellian gas and that molecules on colliding with the inner surface of the shield are first adsorbed, then thermally "accommodated" and finally remitted. A detailed calculation shows that the maximum number of atoms within the shield will be $10^3/\text{cc}$ when the number of atoms in the atmosphere surrounding the shield is between 10^8 and 10^{10} i.e., there is a reduction of the pressures by 10^5 to 10^7 inside the shield. Strangely enough most of these 10^3 atoms/cc are due to the degassing of the shield itself!

The molecular shield can be deployed from a space orbiter or shuttle by an expendable boom (figure 6). The length of the boom will be determined by the magnitude of the density of the gas around the shuttle. The molecular shield

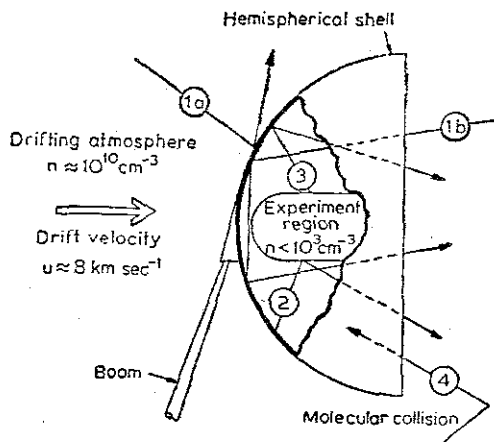

Figure 5. The molecular shield. The drift velocity is 8 km/sec. The atmosphere has 10^{10} atoms/cc. The experimental region on the concave side has only 10^3 atoms/cc. The various processes involved are (1) the atoms in the streaming atmosphere colliding with the shield, (2) outgassing of the inner side of the shield, (3) gas released by the experiment, (4) the gas released by the space vehicle (that pulls the shield) and is scattered into the shield.

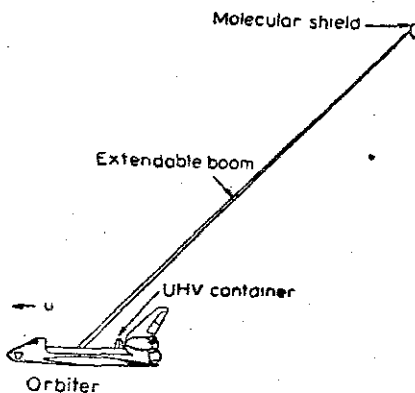

Figure 6. The orbiter deploying the molecular shield.

can also be deployed as a free flier and oriented to take advantage of the gravity of gradients. In fact there is a proposal to put a very large molecular shield ($18 \text{ m} \times 9.6 \text{ m}$) of the free flying type into orbit from a shuttle for the large scale production of silicon solar cells (figure 7). It is estimated that by 1985 about 500 MW/year of electrical power will be generated from solar cells in USA. Assuming a solar-to-electrical energy conversion efficiency of 10% for these cells it has been computed that $5 \times 10^6 \text{ m}^2/\text{year}$ of solar cells will be required. The fabrication of these film silicon solar cells in an orbiting molecular solid by the following method is being contemplated. The substrate is in a real magazine.

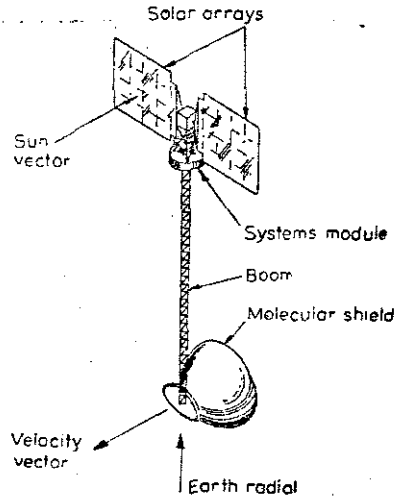

Figure 7. The molecular shield with solar arrays as a free flier.

A low energy electron beam cleans the substrate before silicon is evaporated on to it. The junction is then evaporated. After this the front contacts and anti-reflection coatings are deposited. The cells are finally wound on to another magazine. It is estimated that 10 such cylindrical molecular shields would be necessary for one year's production of $5 \times 10^6 \text{ m}^2$ of silicon cells. It is claimed that when silicon solar cells are prepared in a molecular shield orbited from a space shuttle, the cost of production would be lower than that for cells made on the earth!

10. The space shuttle

The United States of America is planning a reusable facility called the space shuttle. When operational it would be possible to put a variety of payloads into orbit inexpensively. The space shuttle system consists of the orbiter, an external tank containing the ascent propellant, and two solid rocket boosters (SRB). The orbiter's main engines and the two SRBs will fire in parallel at lift-off. The SRBs will be jettisoned after burn-out and can be recovered by a parachute system. After orbital operations the orbiter can "reenter" the earth atmosphere and land on the earth in a manner similar to any aircraft. The nominal duration of a mission is 7 days but it can be extended to as long as 30 days if the necessary consumables are added.

The primary mission for the space shuttle is the delivery of payloads to earth orbit and it can place payloads of 29,500 kg into orbit. The orbiter has the capability to retrieve payloads from orbit for reuse, to service or refurbish satellites in space, and what is most relevant to us, to operate laboratories in space. The space shuttle crew can actually perform experiments in space in what is termed as "shirt sleeve environment". The experimental sample and equipment can be brought back to earth at the end of the mission and used for post-flight analysis.

Table 3. Data on the space shuttle

1. Total system on launch pad	weight 2×10^6 kg length 46 m
2. Space lab—a DC 9 type of plane which returns to earth. It has three main engines each of 470 kilopounds thrust and two orbital manoeuvre system of 6 kilopounds thrust	
3. Weight	29500 to 14500 kg depending on the launch and type of orbit
Dimensions	18.3 m (long) 4.6 m (diameter)
Orbit	Circular or elliptic 200 km–1100 km
Duration	7 days—extendable to 30 days

Table 4. Data on the experimental chamber

Payload weight	5500 kg–9100 kg
Volume (pressurised)	7.6 m ³ to 22.2 m ³
(non-pressurised)	99.8 m ³ to 167.4 m ³
Voltage	28 V d.c. 115/200 V a.c. 400 Hz
Average power	3–5 kW
Peak power	8.8 to 10 kW
Energy	400–600 kWh
Experiment support computer with CPU	64 K core memory with 16 bit words
Data handling	Transmission rate through orbiter storage rate upto 50 MBPS

Some data about the space shuttle and space lab are given in tables 3 and 4 and figures 8 and 9.

11. Possible Indian experiments

India has a definite space programme. It seems quite appropriate for her scientists to give some thought to planning experiments in space particularly as there is a possibility of India getting time and space on the space shuttle. In fact the United States has requested the countries of the world for proposals for performing experiments in space using the space shuttle.

A great deal of thinking is going into the nature of scientific and technological experiments that are to be done in space by the American and European scientific communities. There is some discussion as to whether these experiments must be oriented towards the understanding of phenomena or towards making immediate technological progress. The argument advanced in favour of the former is that such basic experiments are essential if any real technological progress is to be achieved. We still have to give serious thought to the types of experiments that India could perform in space in the field of materials and their processing.

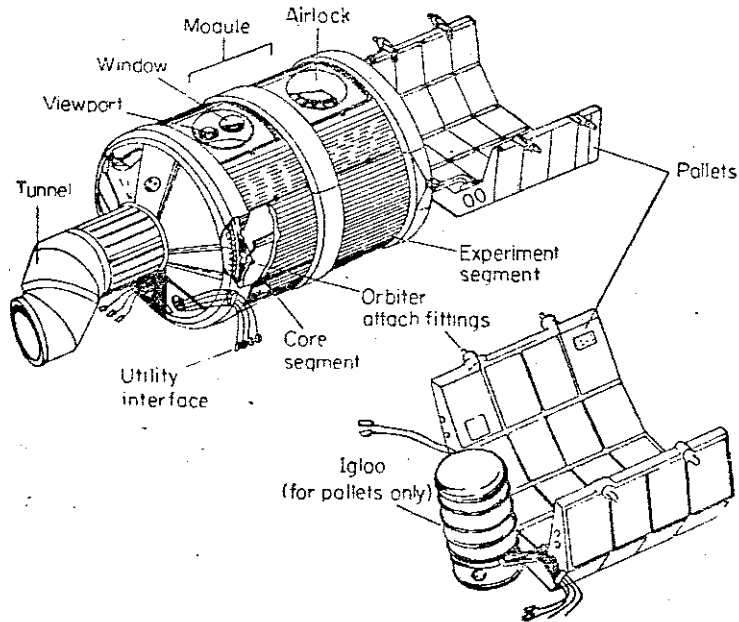

Figure 8. The space module.

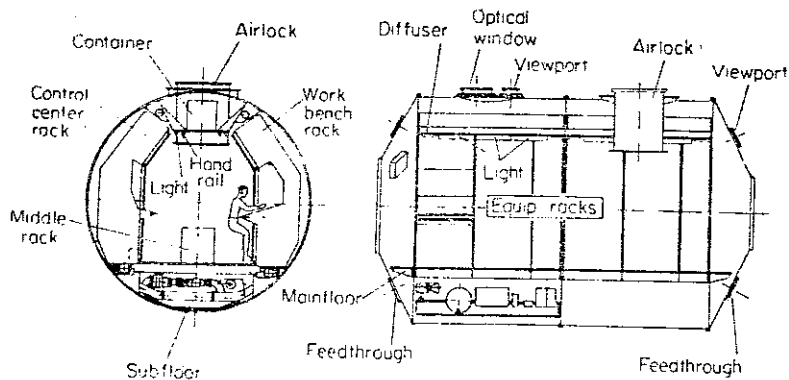

Figure 9. Cross-section of the space lab.

As examples I shall name two experiments which come to my mind. These are related to the research work done in Bangalore. At the National Aeronautical Laboratory, we have been preparing a class of substances called electrocomposites. A powder which may be a ceramic, a plastic or a conducting material is suspended in an electrolytic solution in a bath. When the metal is electrodeposited on a substrate the powder also gets codeposited! The material produced in this manner may be stronger, more wear-resistant, more corrosion resistant, or having better lubricating properties than the metal itself. In fact the properties can be controlled by varying the nature of the suspended powder, or the condi-

tions of electroplating. The exact mechanism of codeposition has not yet been fully understood. Further it is not clear why comparatively larger particles, those greater than $1\ \mu\text{m}$, can increase the strength of a metal by 75% to 120%. Producing these electrocomposites in space would ensure a very uniform distribution of the particulate matter in the electrolyte and hence in the composite. If experiments in space are planned properly, one may possibly get an insight into the mechanisms of deposition and strengthening.

Prof. S. Chandrasekhar and his group at the Raman Research Institute have been interested in the variation of the surface tension of a liquid crystal with direction. Unfortunately the exact measurement of this directionally dependant surface tension is made difficult by the distorting effect of the weight of the liquid crystal drop itself. This would be an ideal experiment to perform in space. This would involve forming a drop of a "single crystal" of a liquid crystal, photographing it from different directions and measuring the curvature of each face and then computing the surface tension. There are many such experiments which may be worth performing.

I thank Dr N Balasubramanian for the helpful discussion I had with him in preparing this article.

References

- Bredit J H and Montgomery B O 1975 *Astronaut. Aeronaut.* **13** 22
Giuli T R 1976 Apollo-Soyuz Science results. *27th Cong. Int. Astronaut. Federation, IAF* 76-149
Anon 1976 Materials science in space. *II European Symp., European Space Agency*
Melgi L T Jr 1976 An orbiting molecular shield facility. *Int. Astronaut. Cong., Anaheim, Calif.*
Yue A S and Yu J G 1974 Solidification of NaCl-NaF eutectic, *AIAA/RSME Paper No. 74-646*