

**RRI-EEG Internal**

**Technical Report :**

**Date :13-05-2019**

**Response of spherical monopole antenna on real earth modelled as slabs of different dielectric constants and conductivities**

**A.Raghunathan**

**Abstract :** The figure of merit of any ground based antenna is significantly influenced by the properties of the ground. So to design such an antenna, it is required that the ground properties should be properly understood. The present report presents the simulation results of spherical monopole antenna placed over the ground modelled as slabs of definite thickness with known varying dielectric constants and conductivities.

**1. Introduction:**

Generally for any antenna, its radiation and impedance properties are governed primarily by the properties of medium surrounding it. For ground based antenna, the electrical properties of earth like dielectric constants and conductivity decide the electrical properties of the antenna. In general, it is difficult to know the properties of real earth. So simulation was carried out in WIPL-D to understand the effect of real earth on impedance and radiation efficiency of antenna. Earth upto certain depth is divided into finite number of slabs and the dielectric constant and conductivity of each of them was varied uniformly one at a time while investigating their influence on return loss and radiation efficiency. Sections below show the simulation results obtained when conductivity and dielectric constant were varied.

**2. Motivation:**

To understand the effect of varying dielectric constant and conductivity on the return loss and radiation properties of the spherical monopole antenna.

**3. Simulation of electrical behaviour of the spherical monopole antenna when placed over the earth of varying properties in the frequency range 50-100 MHz.**

### 3.1. Sphere over real earth of constant dielectric constant and conductivity over the entire depth (Version 82)

This is considered as a reference for comparing the results of simulations involving varying dielectric constants and conductivities.

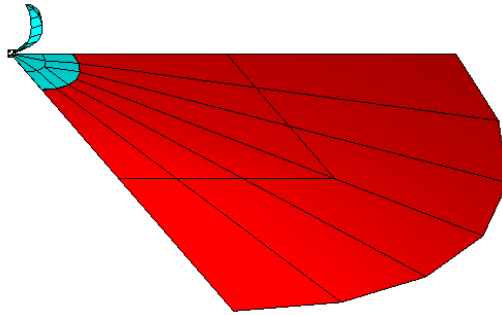

Assumptions about the real earth in the simulation:  $\epsilon_r = 4$ , conductivity=0.0007 S/m; Reflector radius = 834mm; Real earth radius = 6m

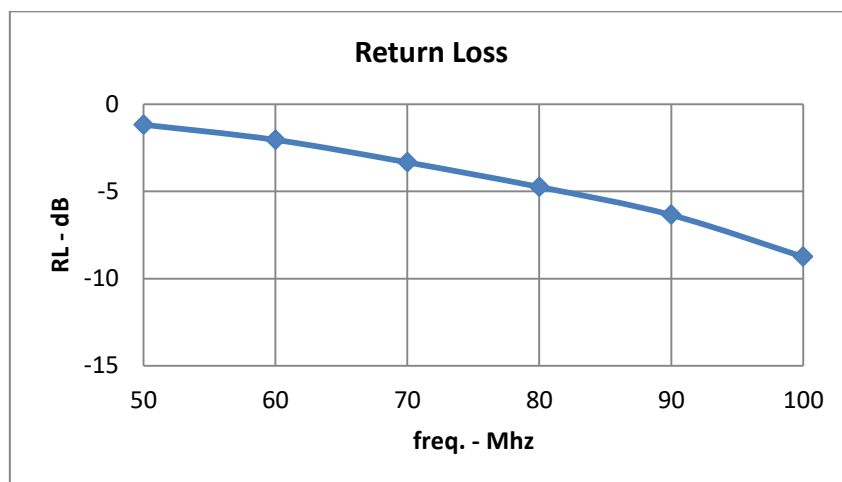

Gain [mU] 80 MHz

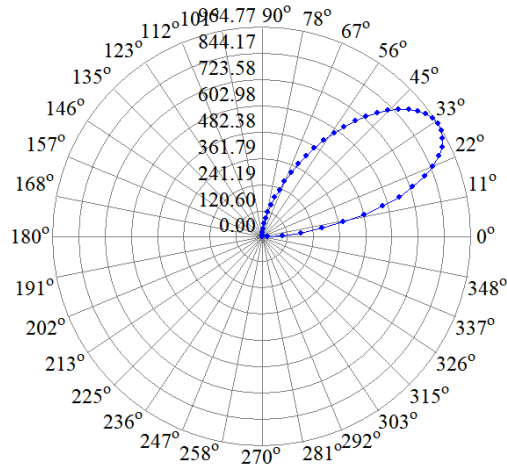

**Radiation Efficiency for spherical antenna over 50-100 MHz**

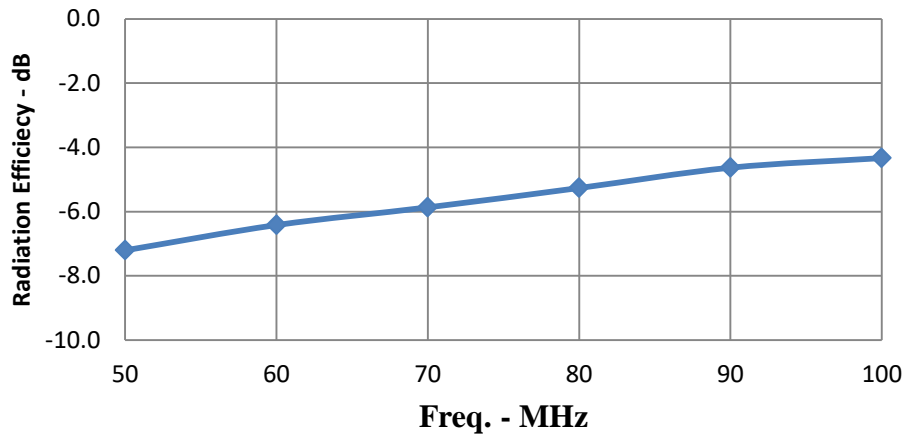

**Total Efficiency for spherical antenna over 50-100 MHz**

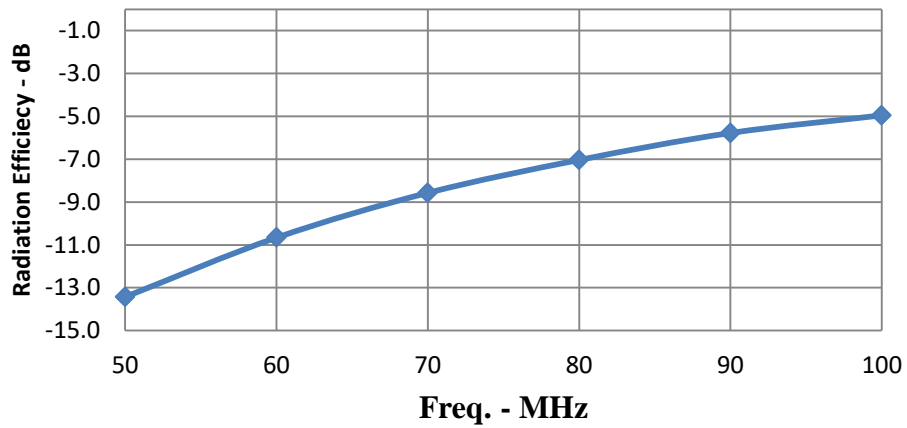

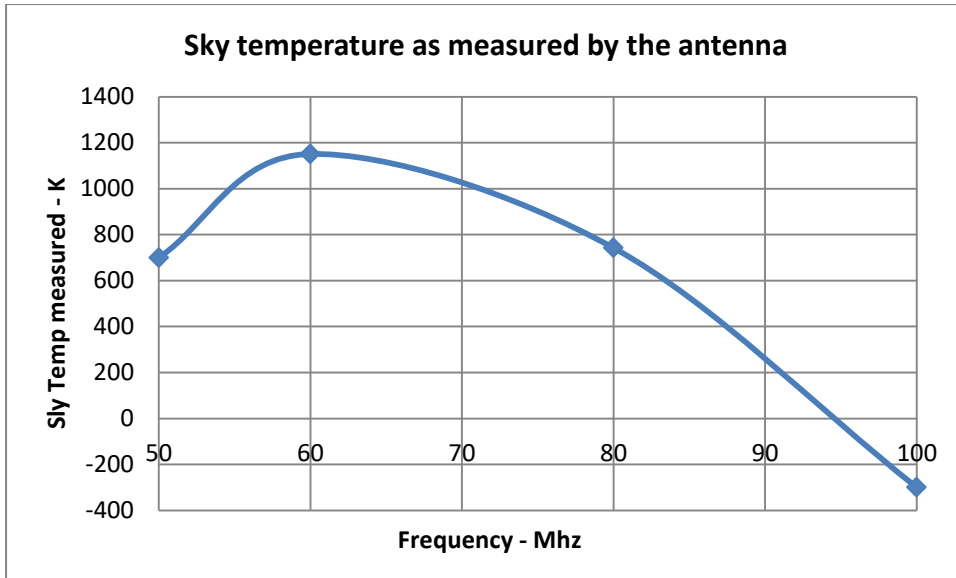

### 3.2. Modelling real earth using slabs of different dielectric constants and conductivities (version 82d)

3.2.1 : Decreasing  $\epsilon_r$  value linearly with depth (2m below the surface) from 4 to 1.5. Conductivity is maintained at 0.0007 S/m throughout.

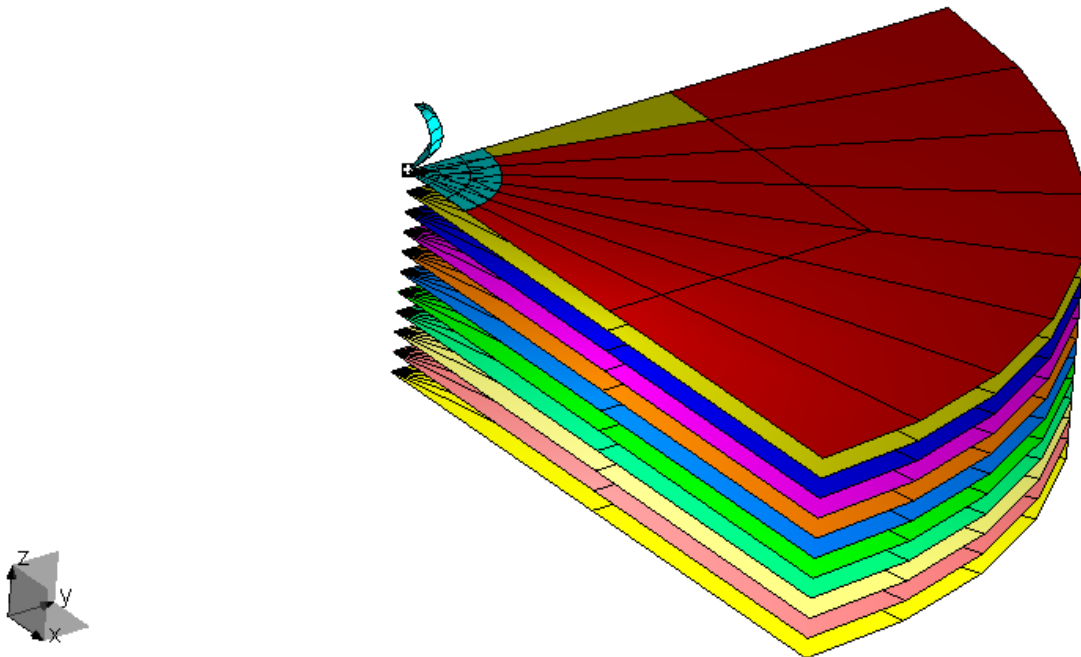

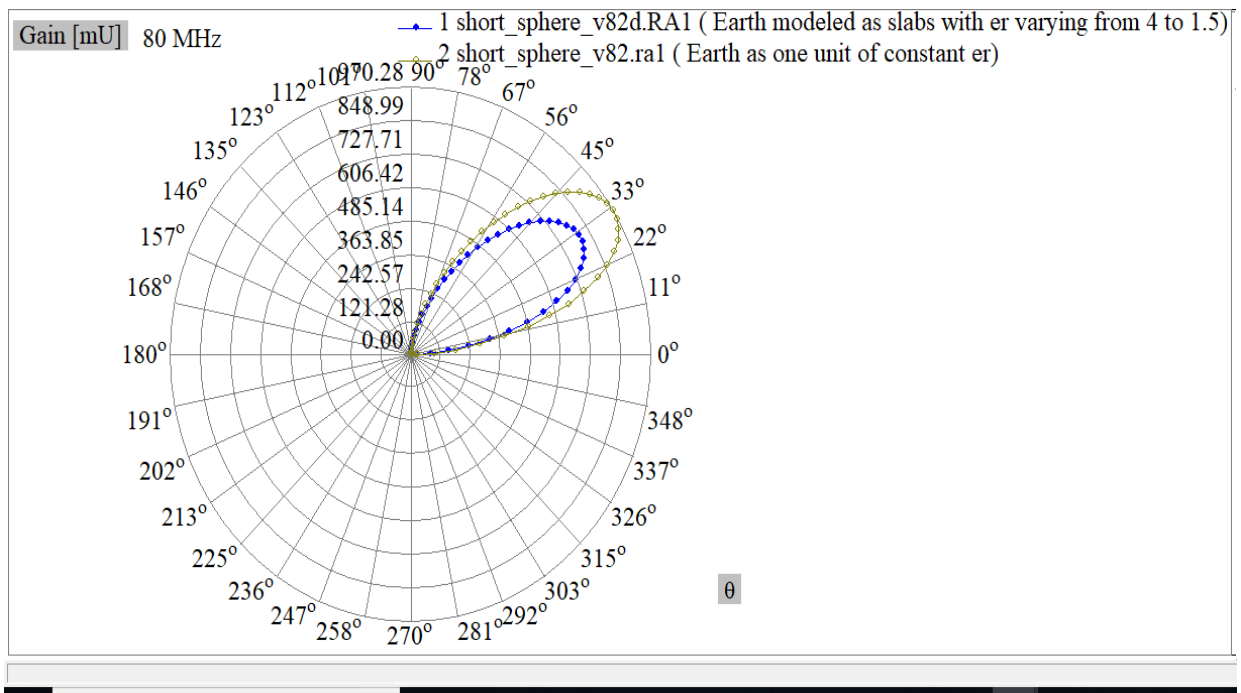
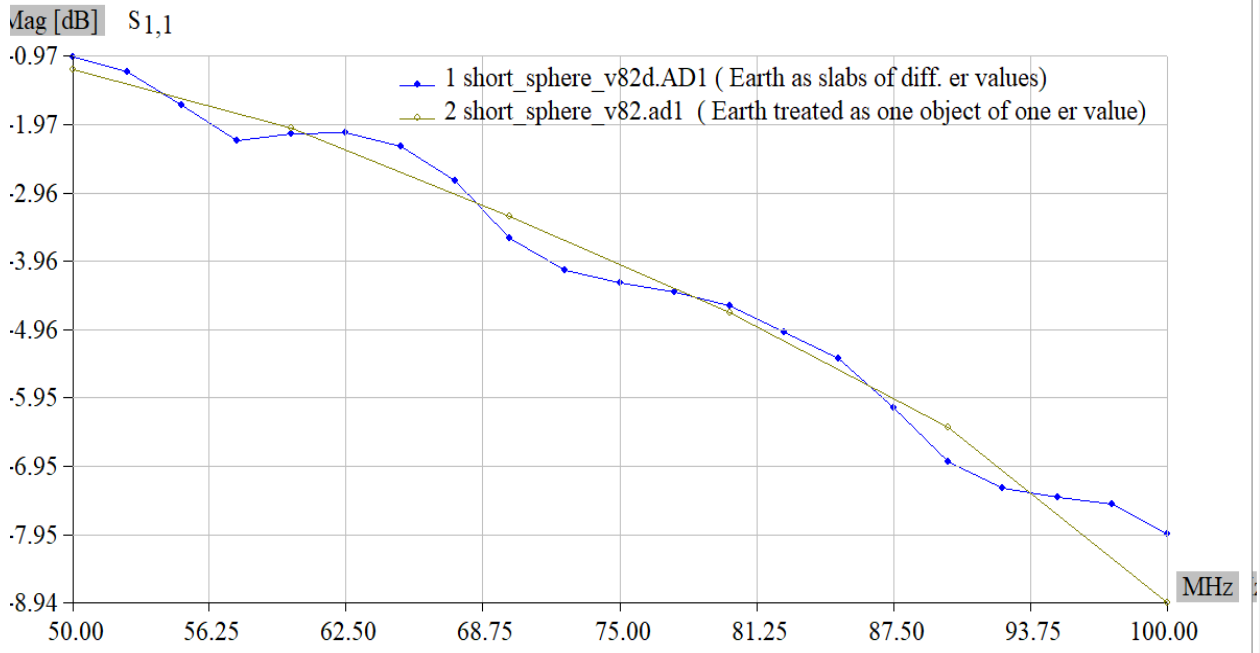

**Radiation Efficiency of spherical antenna with earth modeled as slabs of diff. dielectric constants( $\epsilon_r=4$  to 1.5 and conductivity=0.0007 s/m**

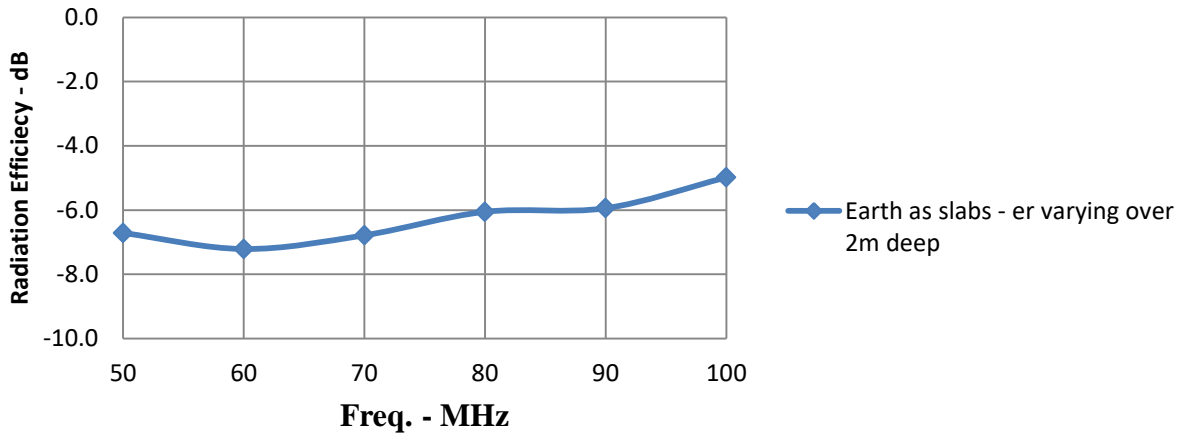

**Total Efficiency of spherical antenna with plate below the real earth ( $\epsilon_r=4$ , conductivity=0.0007 s/m**

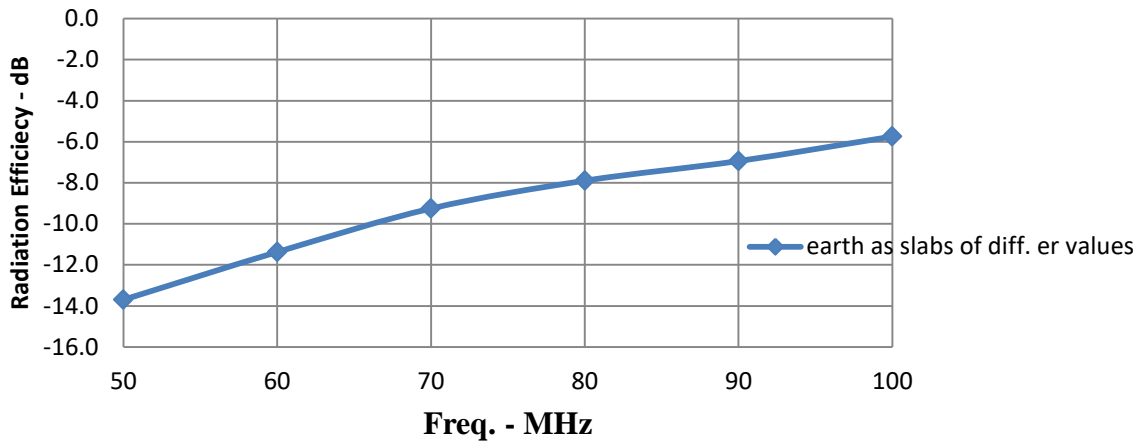

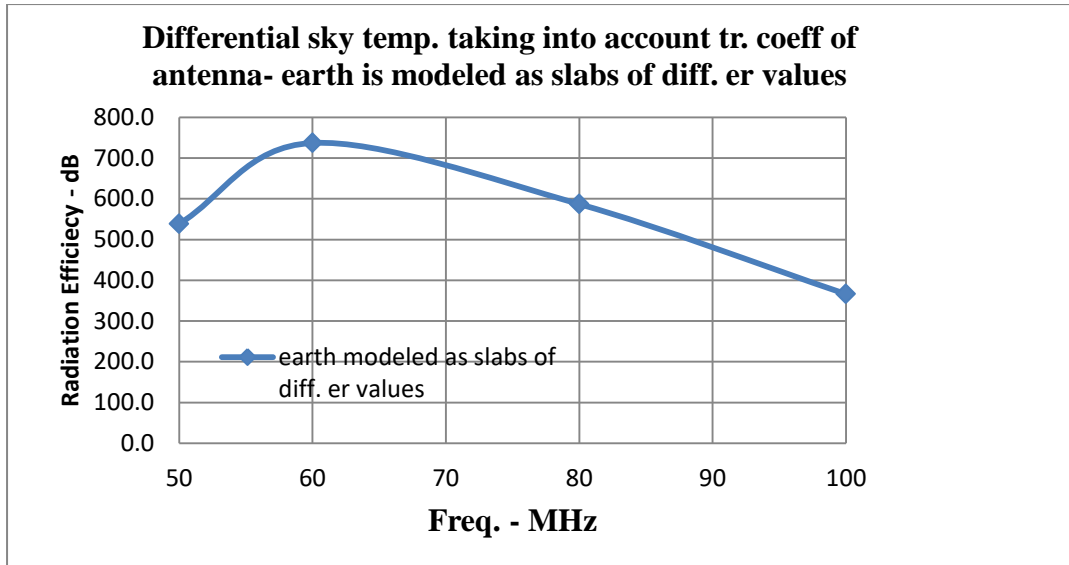

**3.2.2 Increasing the  $\epsilon_r$  value linearly from 4 to 6.5 with depth (2m deep below the surface) Conductivity is maintained at 0.0007 S/m throughout. (version 82 e)**

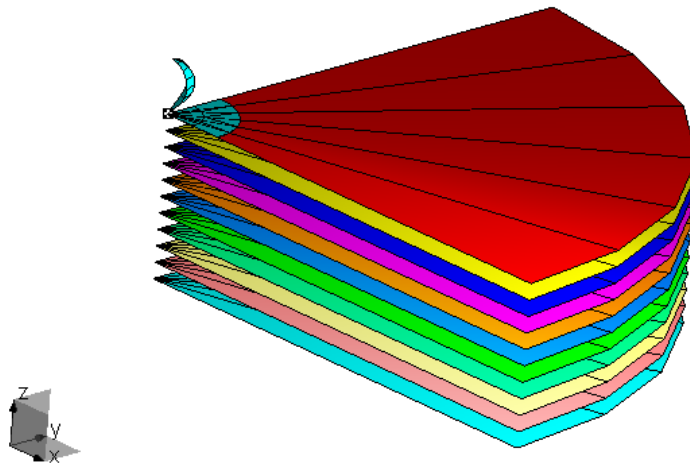

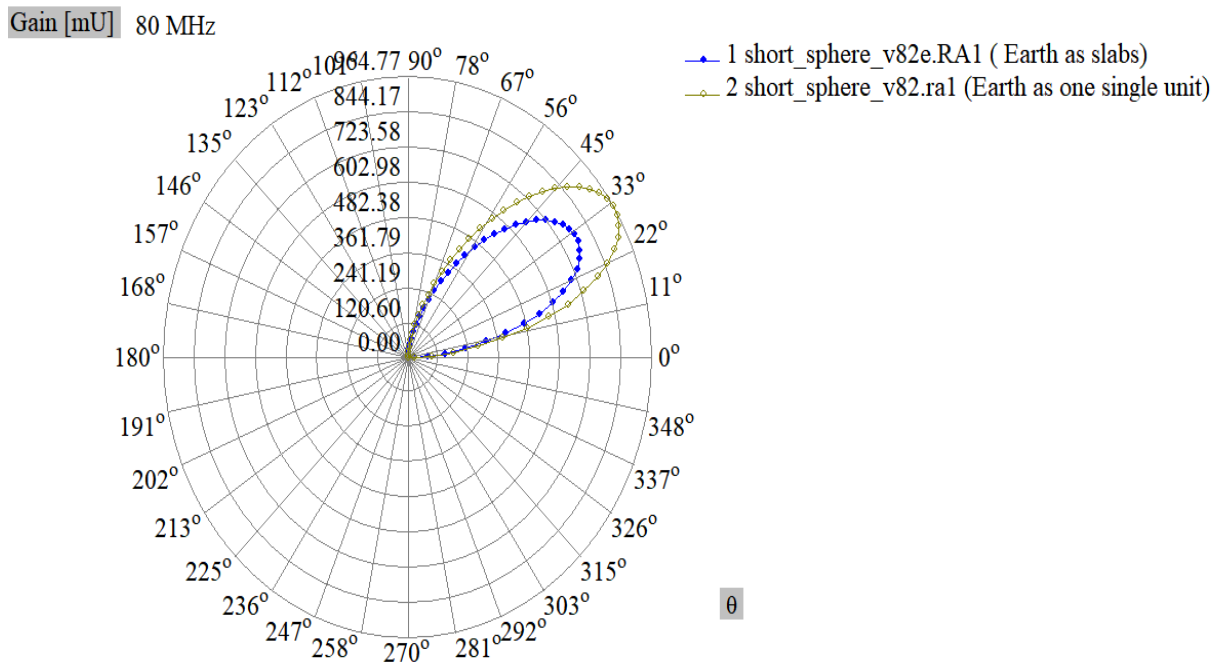
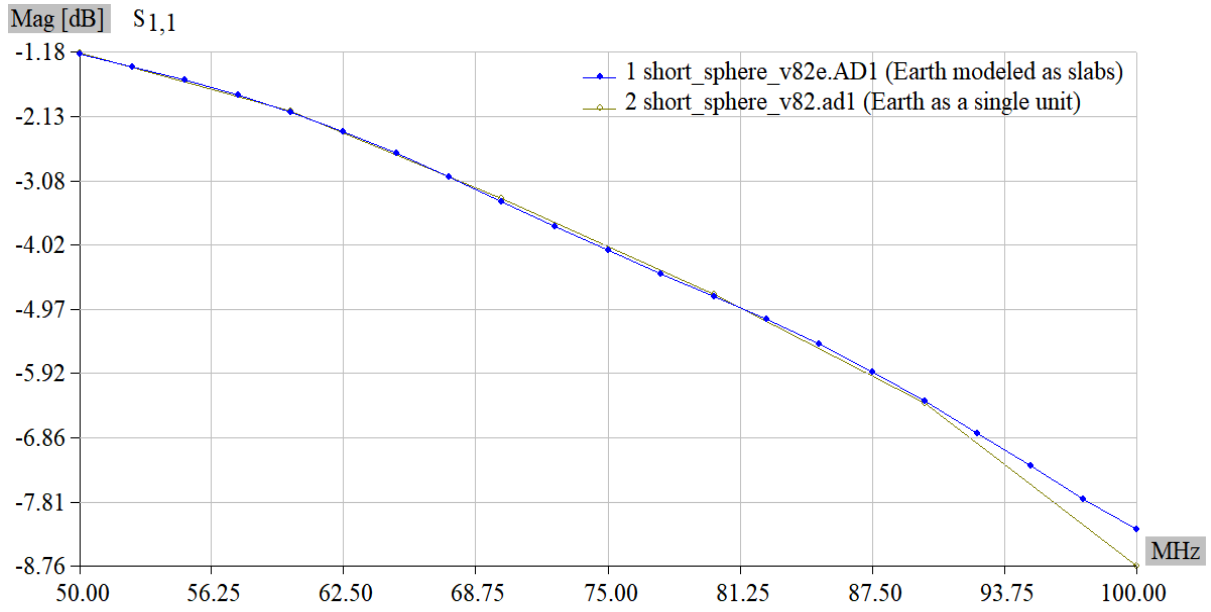



**Radiation Efficiency of spherical antenna with earth modeled as slabs of diff. dielectric constants( $\epsilon_r=4$  to 6.5 and conductivity=0.0007 s/m**

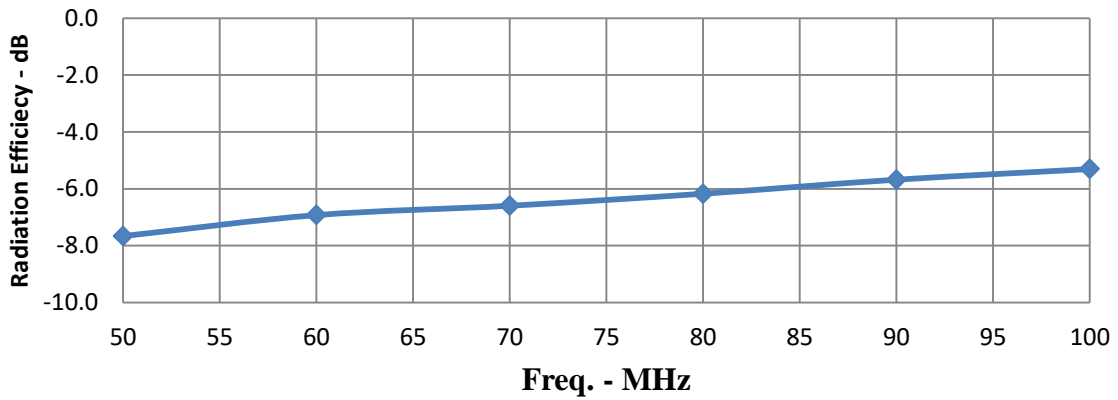

**Total Efficiency of spherical antenna with earth modeled as slabs of diff. dielectric constants( $\epsilon_r=4$  to 6.5 and conductivity=0.0007 s/m**

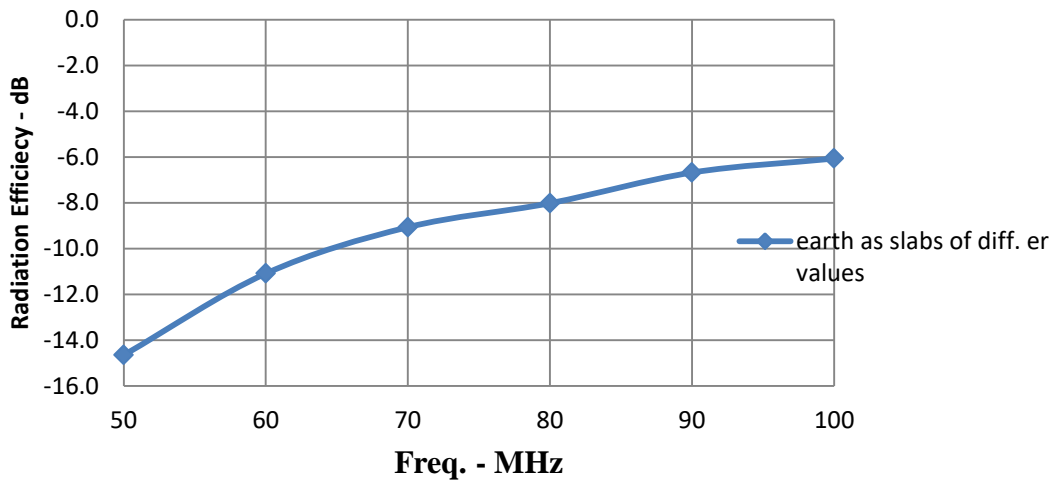

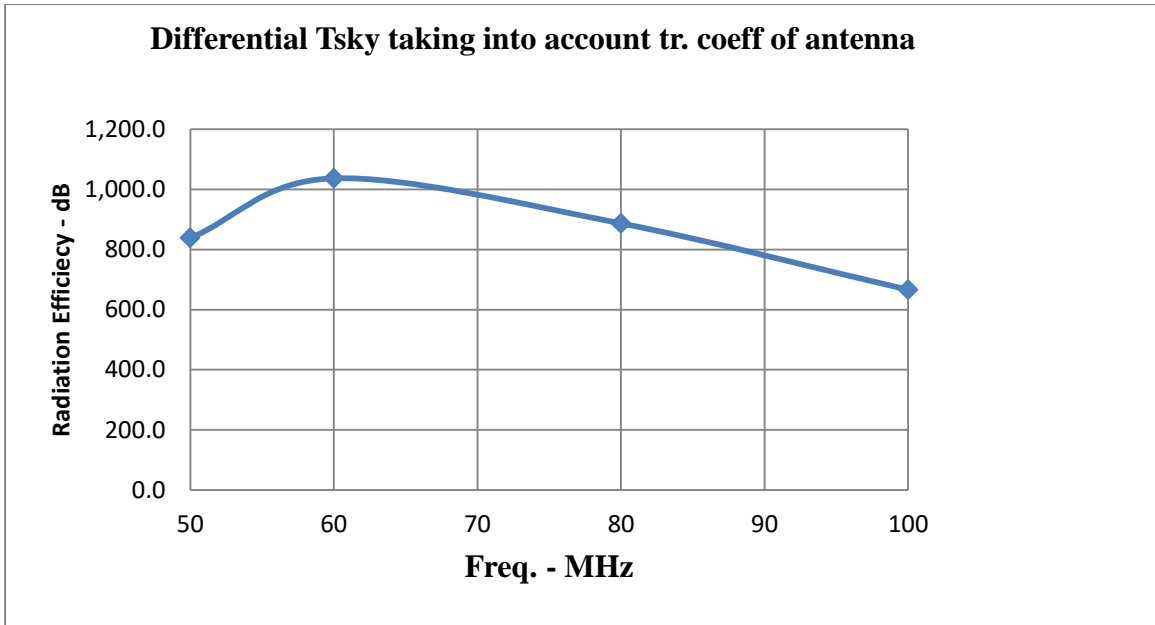

### 3.2.3 Vary conductivity from 0.0007 S/m to 0.07 S/m maintaining $\epsilon_r$ value at 4

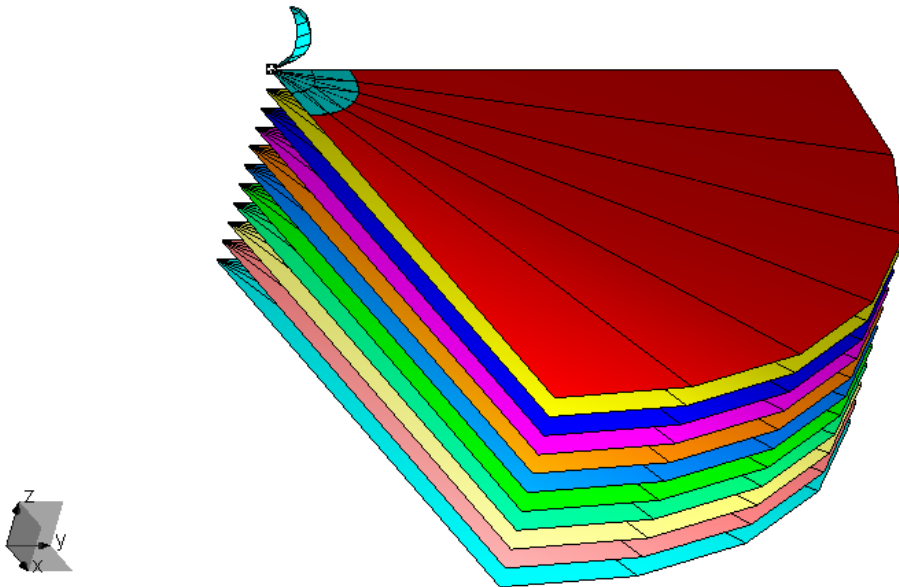

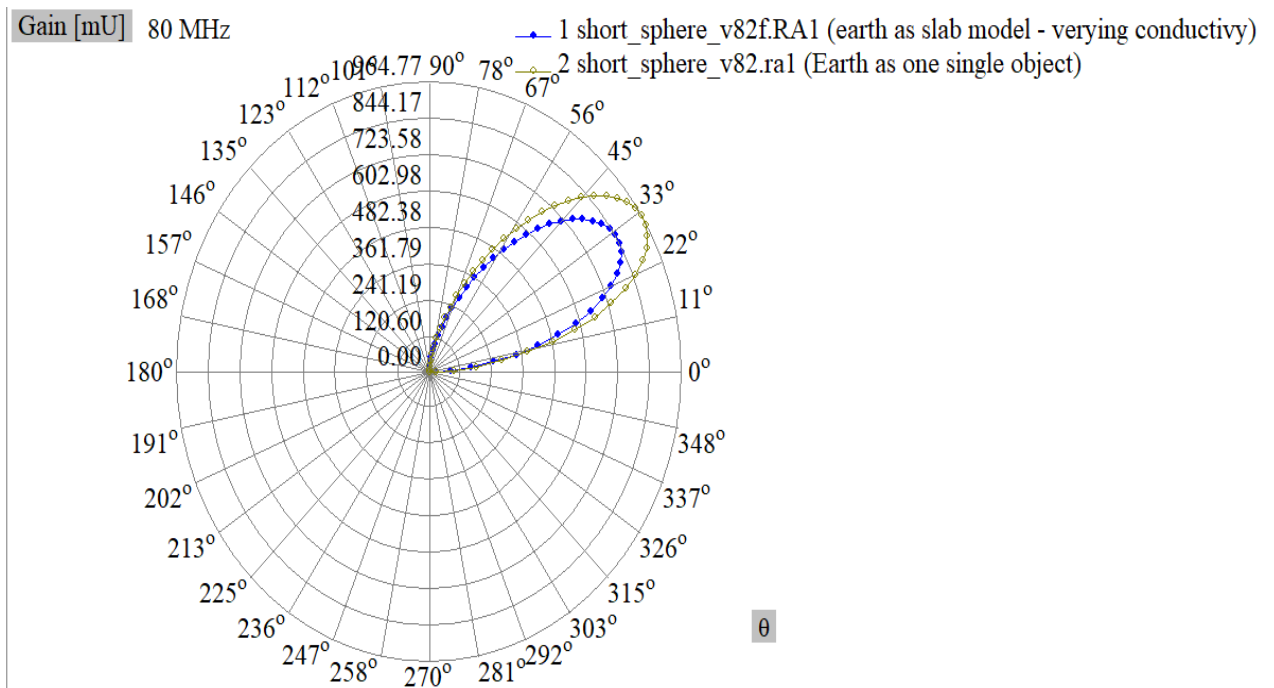
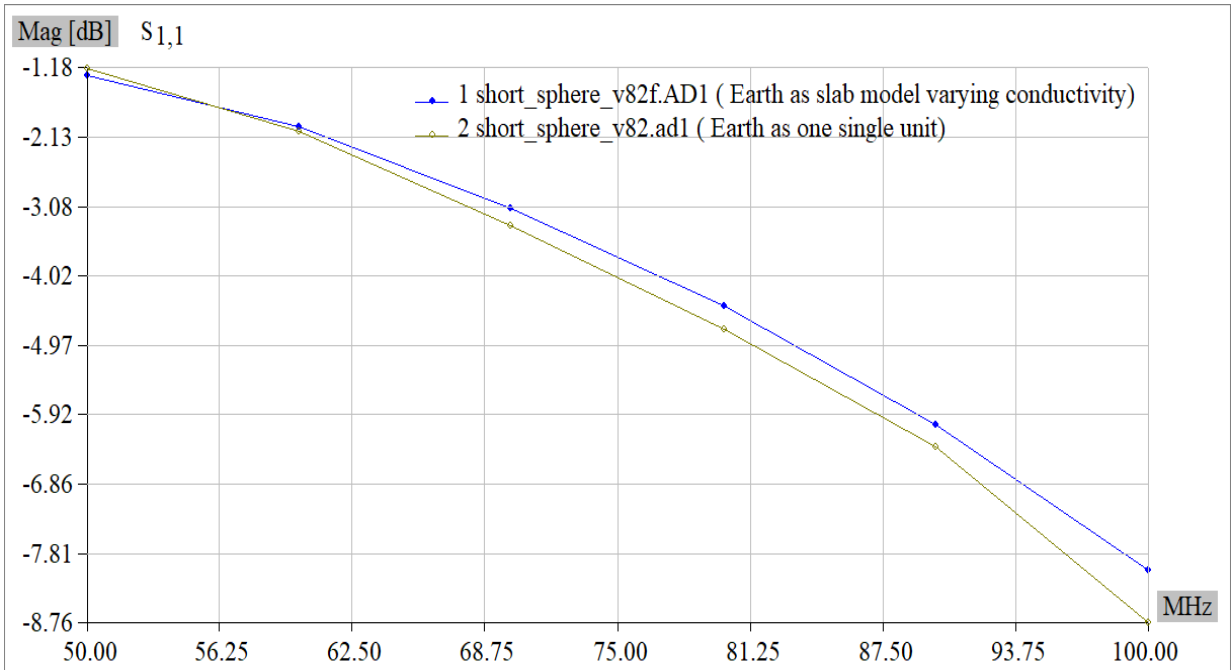

**Radiation Efficiency for spherical antenna over 50-100 MHz**

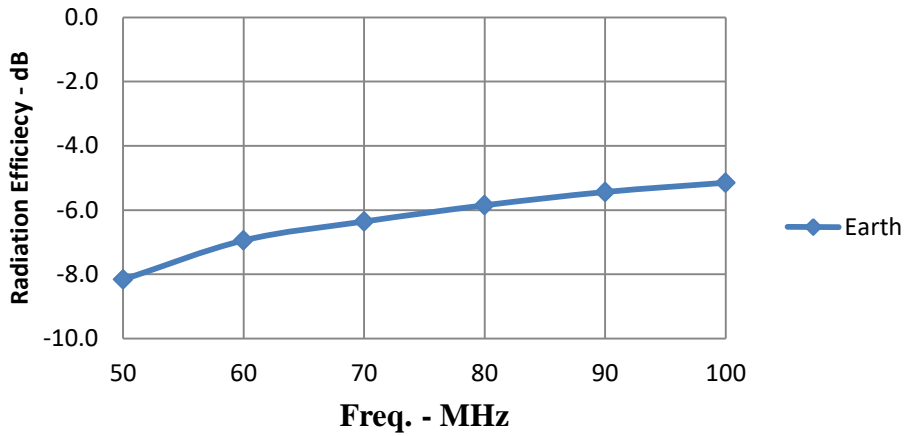

**Total Efficiency for spherical antenna over 50-100 MHz**

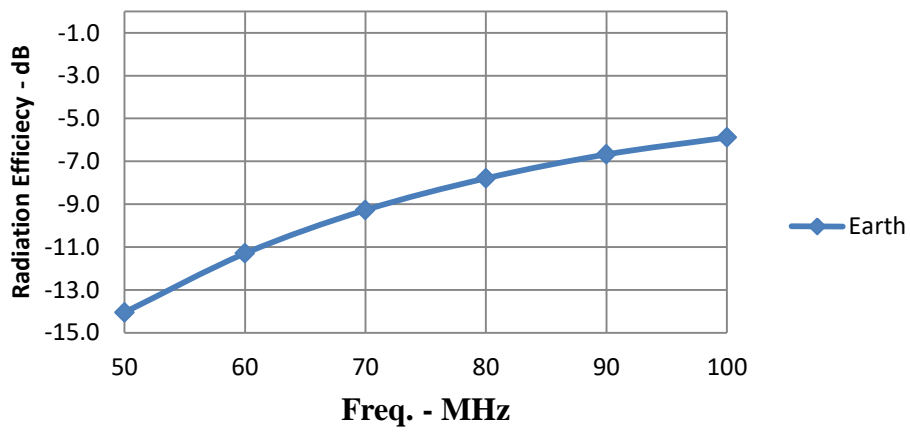

**Differential Sky temp.**

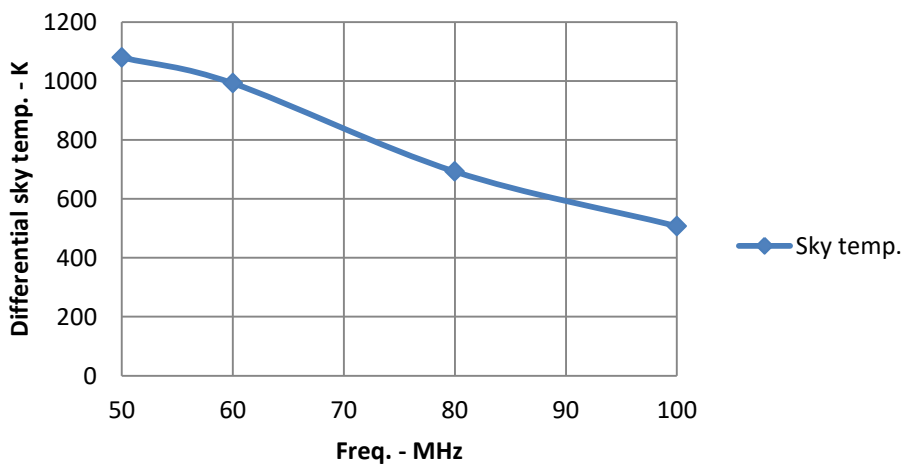

Table:

Sl. No.	Version	Variation of Earth parameter	RL at 50 MHz - dB	Differential Tsky – K at 50 MHz
1.	82	$\epsilon_r=4$ , $\sigma=0.0007$ S/m	-1.18	700 K
2.	82d	$\epsilon_r$ decreasing from 4 to 1.5 over 2m depth with $\sigma=0.0007$ S/m	-0.97 dB with Ripple seen with 0.5 dB p-p	550 K
3.	82e	$\epsilon_r$ increasing from 4 to 6.5 over 2m depth with $\sigma=0.0007$ S/m	Change in RL is very small	550 K
4.	82f	$\epsilon_r=4$ , $\sigma$ increasing from 0.0007 to 0.07 S/m over 2m depth	Slightly increase in RL at 50 MHz. But overall it is poor.	1050 K. But low over most of the band.

## 5. Conclusion

Modelling the earth using varying  $\epsilon_r$  values or conductivities, does result in significant change in the spectral response of return loss. Decreasing  $\epsilon_r$  value results in the pass-band ripple while increasing the conductivity results in slightly poor return loss over the band of 50-100 MHz.