

# **Design of EEG electrodes**

S.Sujatha

Supervisors : Hema Ramachandran, B.Ramesh

## **Abstract:**

One of the critical components in recording EEG signals in a Brain-Computer Interface system is the electrode. These have to faithfully record extremely weak bio-signals, merely by contact. The shape, size and material choice are important parameters that govern the performance, ease of use, and comfort to user. In this report we describe the merits and demerits of the various electrodes that we developed.

## **1. Introduction**

**Brain Computer Interface (BCI)** is a technique of operating devices or performing actions only by use of brain signals, without any physical movement by the subject. A typical BCI consists of a brain signal detectors (electrodes), a bio-amplifier, a signal processor and a device driver. Each of these has to perform very well for reliable functioning of BCI system. This report describes our effort to develop low cost electrodes for use with BCI systems. The various designs and the relative merits are discussed.

An electroencephalogram (EEG) is the waveform obtained when electrodes are placed externally on the scalp of the subject, and it represents the electrical activity within the brain. There are millions of neurons in the brain which neurons fire electrically either to record perceptions of senses or to initiate action e.g. speech, movement of limbs etc. Different sets of neurons fire for different tasks. A typical EEG waveform is the recording of the incoherent sum of all the potentials generated by the firing of the various

neurons. In fact, it is the recording of the leakage of these potentials through the brain, through the skull and through the scalp, onto the electrode.

The EEG signals are very weak, typically 100nV-10 $\mu$ V (M. Teplan, 2002). These weak signals have to be recorded and the component of interest (say visually evoked potentials) has to be extracted. Therefore it is essential that the electrodes tap these potentials reliably, repeatably and with low introduction of noise. This is quite demanding considering the signals are weak, and that the electrodes are merely placed on the scalp and are liable for easy displacement due to formation of sweat layer etc.

### Electrode Placement:

EEG electrodes are normally placed on the scalp according to the international 10-20 electrode system (see Fig.) . Two anatomical landmarks are used to define the longitudinal axis over the scalp: first, the nasion (Ns), which is the depressed area between the eyes where the bridge of the nose joins the forehead; second, the Inion (In or Iz), which is indicated by a bump at the lower rear part of the skull. From these landmarks, Ns-In perimeters are divided into 10% and 20% intervals and electrode locations are fixed at those division points (Jasper, 1958). A combination of a letter and a number is used to identify each electrode location. The letters F, T, C, P and O respectively denotes Frontal, Temporal, Central, Parietal and Occipital lobes. Electrodes over the left hemisphere are suffixed with odd numbers and those over the right hemisphere are suffixed with even numbers.

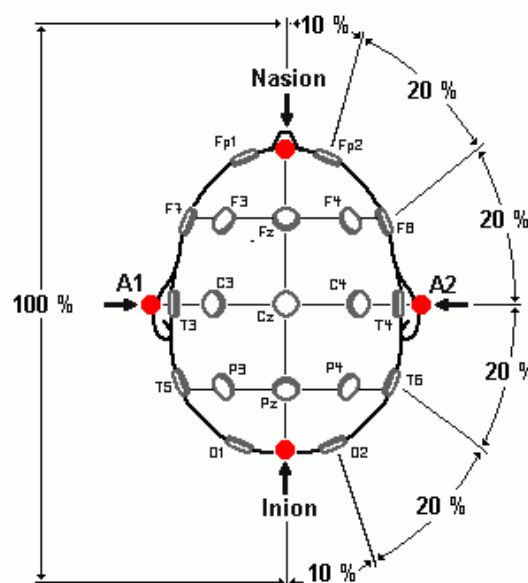

## **Recording EEG:**

EEG is defined as potential differences between pairs of electrodes placed on various scalp locations one of the electrodes is generally called signal electrode while the other is defined as the reference electrode. A good contact between the scalp and the electrodes is important to improve the signal to-noise ratio (SNR) of the acquired signals. Therefore a layer of conductive paste is generally applied before recordings to reduce the skin-electrode impedance.

## **2. Motivation**

Our ultimate aim is to build a low-cost BCI system, where each component has to be inexpensive, while still offering high quality performance. Only then can a BCI system be affordable to an average Indian patient. High quality but expensive electrodes can indeed be imported. The aim has been to build and test simple good quality electrodes in-house for recording EEG.

## **3. Description of the work**

Several types of electrodes were made and tested. The making of an electrode involves the following steps :

- Selection of material
- Designing the shape
- Determination of electrical parameters
- Active / passive selection
- Testing on test bench
- Testing on subject

### **Selection of Material :**

The electrodes are usually made of a good conducting material and coated with gold. As gold is chemically inert, a good coating with gold yields electrodes whose performance does not degrade with time. On the other hand, Al and Ag are good electrical conductors. However, these are prone to oxidation, and their performance degrades quite rapidly (even

hours). We therefore decided to fabricate electrodes in copper, for ease in machining, and fairly good conductivity. However, we gold-coated the electrodes. Coatings were applied either in-house, or at commercial establishments. The performance of the electrodes depended quite critically on the purity of the coating, and on its thickness.

To verify the elemental composition a sample of in-house fabricated gold coated cup electrode was tested at SCM lab, from the power spectrum one can determine the structure. Below table gives the element present and its weight in percentage.

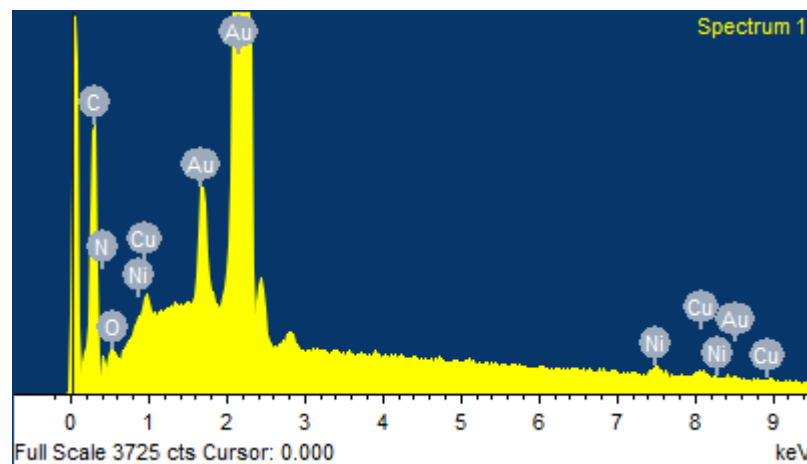







Element	Weight%	Atomic%
C K	15.98	67.66
N K	2.14	7.76
O K	0.78	2.49
Ni K	1.17	1.01
Cu L	0.82	0.66
Au M	79.10	20.42
Totals	100.00	

The gold cup electrodes are effective in measuring EEG.

### Designing the shape :

The parameter that is most important in designing the shape is the surface area. A large area is good for collecting the signal. However, a large electrode is difficult to place and maintain its positions. Also, as the head is curved, but electrodes have nearly flat bases, the area of contact may turn out to be quite small. We therefore tried a number of novel shapes, as shown in Table 1, below.

Electrode Type	picture	Description	Merits/Demerits
Cup electrode		These electrodes comprised of a circular gold plated copper head of 15mm diameter, with a thick extension at the edge that holds the electrode cable connected to it. This design has depression in the centre to hold the conductive paste.	These electrodes are easy to fabricate and montage easily. They have to be cleaned after use using ultrasonic cleaner and wiped clean to retain the shiny surface and stored in a container. Electrodes have to be replaced with the new ones if the gold plating wears out.
Flower Electrode		Flower electrodes, had petal-like structures which made contact with the scalp. This shape is extruded out of 15mmX15mm size copper plate and later gold plated. The Electrodes were mounted on the scalp using the conductive paste for acquiring the signals.	These electrodes were designed larger areas on scalp. Same cleaning and storing method as above. Demerit: Electrodes had to be replaced with the new ones if Gold plating wears out
Disposable cup electrode		These cup electrodes are made up of copper similar to gold cup electrode. Instead of being Gold-plated, these electrodes are wrapped with a thin aluminium foil and placed on scalp using conductive paste.	After the usage, the aluminium foil would be taken off and disposed retaining the copper electrode for next use. Thus there was also no maintenance. Demerits: The signal obtained was not desired EEG signal. Possible reasons could be the fact that when the aluminium foil was wrapped around the electrode surface, there were many wrinkles in the foil that would attenuate the EEG signals being acquired. For acquiring the desired EEG signals, the electrode surface should be smooth and shiny.

Passive Porcupine electrode		These electrodes comprise of a circular FR4 substrate plate on which holes are made symmetrically along the circumference for the gold plated copper pins to be mounted on one side. These pins would make the contact with the scalp surface for tapping potentials.	The EEG signals couldn't be tapped using these electrodes. The possible reason could be that these electrodes did not involve neither the conductive paste or the active circuitry for improving the signal acquired.
Graphite Electrode		These electrodes comprise of a stainless steel round shell connector in which on one side, the graphite pins are arranged in a circular fashion along the edge of the connector	These electrodes when tested, were not conducting the EEG signals when they had been mounted over the frontal region but, they could acquire the Myo-signals due to the eye blinks.
Active Porcupine electrode		Active electrodes make use of a small built-in circuitry to amplify the signals before the EEG signals enters the bio-amplifier. The electrode assembly involved gold plated copper pins mounted along the circumference of a circular gold plated copper plate to give the structure of a porcupine such that these pins make a good contact with the scalp surface between the hair when mounted without any usage of a conductive paste.	These electrodes can be placed on scalp easily, no paste is required. The performance is comparable to cup electrode. Demerit: Tricky to fabricate, longer recording hours is difficult because of the structure. As the electrode contains active circuitry, protection of the patient from any hazard of electric shock to be taken care.
Indium Tin Oxide electrode		ITO coated glass is used due to its one main property, i.e Its electrical conductivity Each electrode comprises of a 13 x 13 mm square glass substrate coated with a layer of ITO which would be making the contact on the scalp when it has been mounted using a conductive paste . The conducting side of the electrode is given a concave structure at the centre to hold the conductive paste. material that was available here and also the non-corrosive nature of ITO layer.	The ease of manufacturing them with the raw material available in-house and also the non-corrosive nature of ITO layer.  Demerits: these electrodes did not conduct the EEG signals. The possible reason for this could be the shape of the electrode where in the concave structure would extend into the ITO layer thereby producing a non-conducting region at the centre.

### Active and Passive Electrodes :

There are two types of electrodes, active and passive electrodes. The active electrodes contain an amplifier built within it. These electrodes are used to reduce the noise and cable interferences. On the other hand, passive electrodes do not include any amplifiers built with in the electrodes. We built both active and passive electrodes.

### 4. Fabrication details of the Active Electrode :

The active porcupine electrode structure is built in a such way that the active circuitry is on one face of the electrode and on the other face gold plated pins are arranged in circular fashion to form an electrode. These pins, which make make contact with the scalp, even in the presence of thick hair, tap the potentials. The potentials are fed to the input of the on-electrode amplifier, which amplifies by gain of 10 and later on these amplified EEG signals are connected to the input of bio-amplifier for further amplification and filtering of the signals fabrication details are given below:

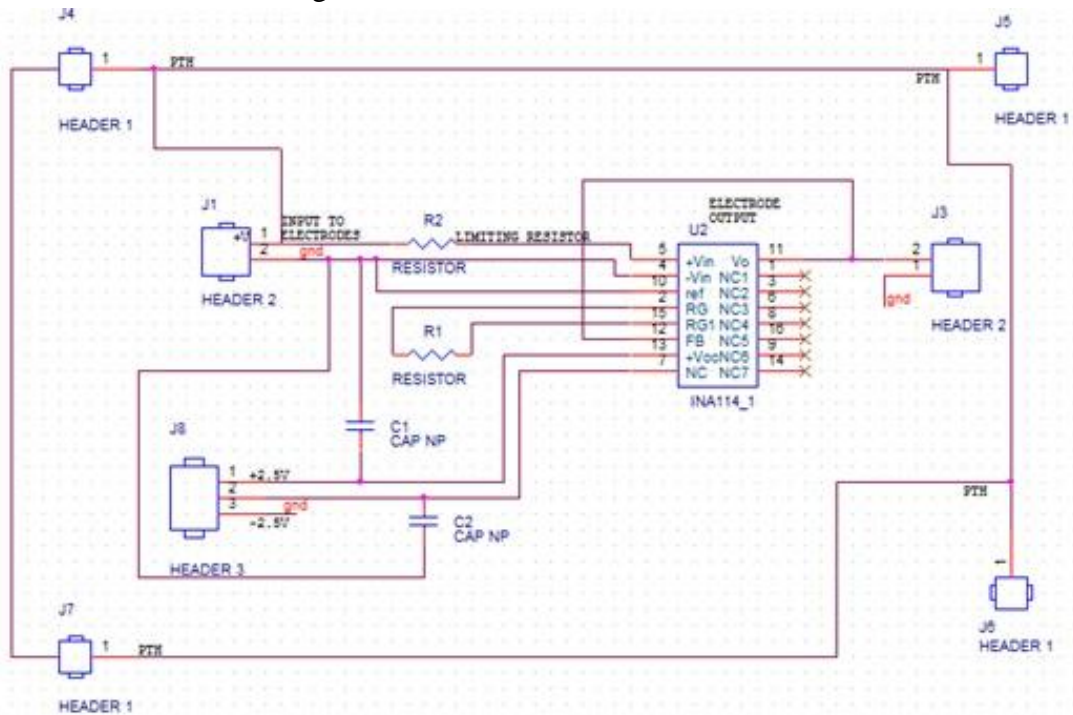

Fig. 1: Active circuitry schematic diagram

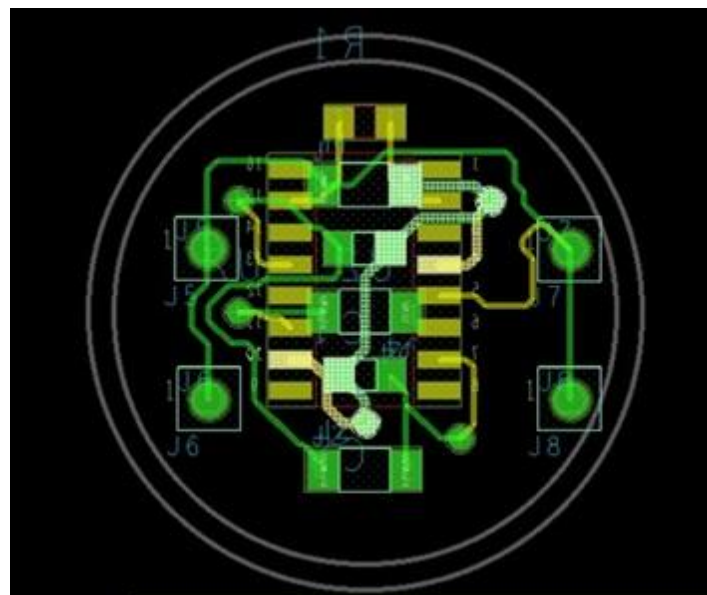

Fig. 2: PCB Layout design for active circuitry

The above layout was designed using Allegro software and the circuitry was verified, it was also fabricated in-house and the assembly of the board was carried out.



**Fig. 3: circular plate with holes for mounting pins**

For the porcupine structure the pins of 15mm length, are assembled on to the circular plate of 20mm diameter and soldered. The dimensions were restricted in order to build smaller electrodes.

## **5. Measurement Results :**

First, the performance of the electrodes was measured on a test bench, and thereafter on volunteers.

### **Determination of electrical parameters :**

The components used to build active electrodes are instrumentation amplifier INA114, SMD capacitors and resistors.

#### **FEATURES OF INA114**

- Low Offset Voltage: 50 $\mu$ v Max
- Low Drift: 0.25 $\mu$ v/ $^{\circ}$ C Max
- Low Input Bias Current: 2na Max
- High Common-Mode Rejection: 115db Min
- Input Over-Voltage Protection:  $\pm$ 40v



- Wide Supply Range:  $\pm 2.25$  To  $\pm 18$ v
- 8-Pin Plastic And Sol-16

Depending on the gain required the the gain resistor  $R_g$  is set accordingly, the gain value set here is 200.

### **Testing on a test bench :**

Once the active electrode is assembled and power supply connections are made, a test bench set-up consisting of signal generator was set to sweep frequencies from 1Hz to 60Hz, input amplitude set to 1mv level and voltage output is measured to calculate gain. Also input voltage was varied in steps of 2mv for given fixed frequency and corresponding changes in the output voltage was measured. The average gain obtained was 210.

### **Testing on a subject :**

To validate the performance of the above tabulated electrodes, volunteer were trained in for Steady-State Visual Evoked Potential recording. A steady-state visual evoked potential (SSVEP) is a response to a repetitive visual stimulus, provided as a blinking source of light, coming on and off a a fixed frequency. This elicits a response in the visual cortex at the same frequency, which can then be extracted from the EEG signal by a fourier transform.

The following steps are taken, in order to measure the EEG, and evaluate the performance of the electrodes :

- ✓ The subject is seated comfortably.
- ✓ The location of the EEG electrode placement is marked on the scalp, based on 10-20 electrode position system.
- ✓ The EEG electrodes were mounted on the scalp surface of the subject under test by placing the electrode at desired location, with conducting paste providing electrical contact as well some amount of adhesion.
- ✓ The electrode cable is then connected to the Bio-amplifier along with a reference signal also being acquired by another passive electrode positioned on the left or right ear.
- ✓ The bio-amplifier amplifies the signal from the electrode from micro volt range into a volt range. The amplifier has gain between 1000-1000, 000 and has common mode

rejection ratio of 110dB. The Analog filters are high pass filter with cut-Off of 1Hz and a low pass filter with cut-off frequency of 35Hz and a 50Hz Notch filter is used to cut-off the power line interference signal.

- ✓ The output signal is digitized by an Arduino Uno board and the EEG is recorded and processed by a custom MatLab program for computing their frequency spectrum.

## 6. Results :

Below plots show the frequency spectrum obtained by setting up the experiment explained above to test the performance of above tabulated electrodes.

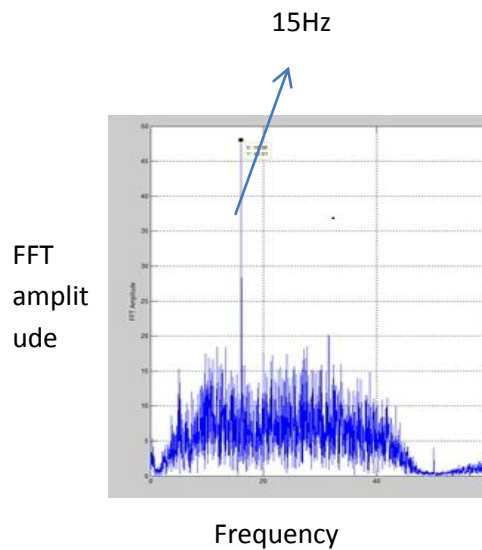

**Fig. 4: Frequency spectrum of EEG signal acquired using in-house Gold plated Cup Electrodes**

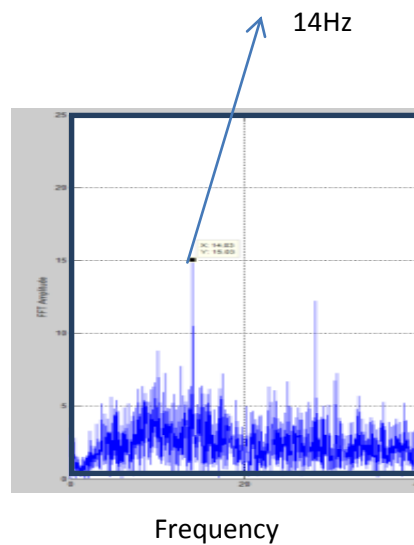

**Fig 5: Frequency spectrum of EEG signal acquired using In-house flower shaped electrode**

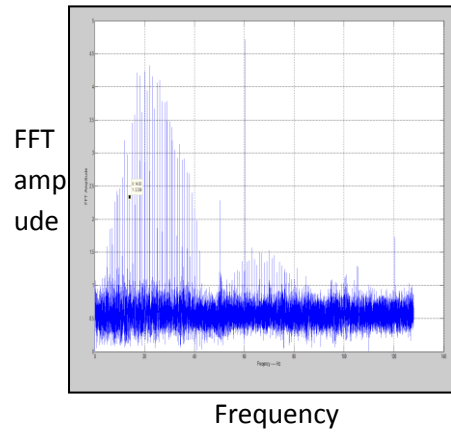

**Fig. 6: Frequency spectrum of Signal obtained from in-house Copper-Aluminium Cup Electrodes**

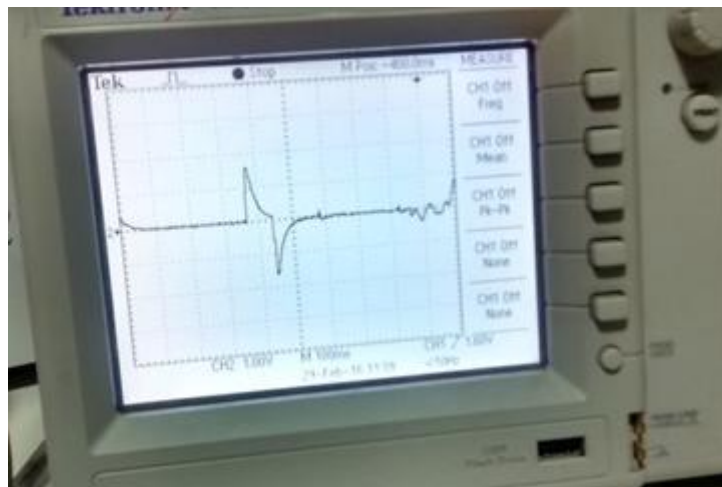

**Fig. 7: Waveform of signal obtained using Graphite cup electrode during eye-blinks**

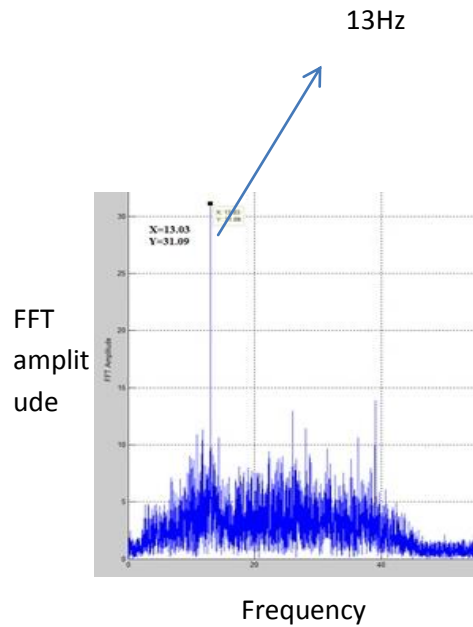

**Fig. 8: Frequency spectrum of EEG signal acquired using in-house Active Electrodes**

## 7. Conclusions:

All the above passive and active electrodes were designed, built and tested, the performance of passive cup electrode produced good results. As the electrodes were fabricated and gold plated in-house, they could be replenished at ease when the electrodes used to wear out over long usage and cleaning.

The electrode should have a smooth surface and shiny finish for it to tap EEG signal, care to be taken during cleaning and storing.

The montage is easy and EEG signal recording for 30min were carried out.